

Instruction Manual

Pearl Rotary Joint

AC Series

This instruction manual applies to products with type designations that begin with AC.

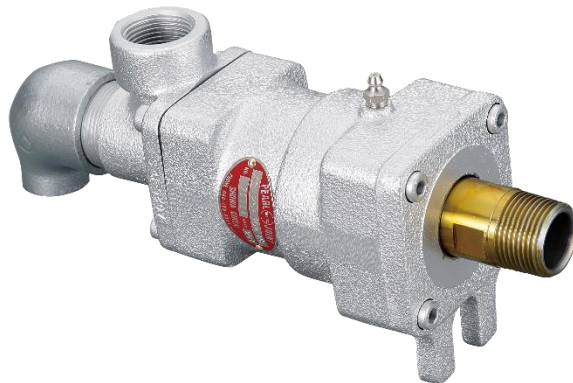

This instruction manual describes important precautions for preventing accidents and how to handle the product. To ensure safe use, be sure to read this manual and fully understand its contents before using this product. Store this manual carefully so that it can be referred to at any time.

Pearl is a trade name of Showa Giken Industrial Co., Ltd.

Table of Contents

| | |
|---|-----|
| 1. How to Read Nameplate (Nameplate Information) | P3 |
| 2. For Safety | P3 |
| 2-1) Symbols | P3 |
| 2-2) For safe use | P3 |
| 3. Product Overview | P4 |
| 3-1) Application | P4 |
| 3-2) Information indicated by model names | P4 |
| 3-3) Service conditions | P5 |
| 3-4) Precautions for use | P5 |
| 3-5) Product structures and materials | P6 |
| 3-6) Product dimensions | P6 |
| 3-7) Product masses | P6 |
| 3-8) Accessories | P6 |
| 4. Transport and Storage | P7 |
| 4-1) Transport | P7 |
| 4-2) Storage | P7 |
| 5. Installation to Machinery | P8 |
| 5-1) Installation procedure | P8 |
| 5-2) Internal pipe installation (for duplex only) | P8 |
| 5-3) Siphon pipe, Siphon elbow (for duplex, stationary IP only) | P10 |
| 5-4) Installing to a roll | P12 |
| 5-5) Pipe laying | P14 |
| 5-6) Measures for preventing rotation | P15 |
| 6. Removal from Machinery | P16 |
| 7. Operation | P17 |
| 7-1) Operation | P17 |
| 7-2) Operation shutdown | P17 |
| 8. Inspection and Maintenance | P18 |
| 8-1) Daily inspection | P18 |
| 8-2) Greasing | P18 |
| 8-3) Repair and replacement of consumables | P19 |
| 9. Troubleshooting | P20 |
| 10. Disposal | P21 |
| 11. Product Warranty | P21 |
| | |
| A. Appendix – How to Repair or Replace Consumables | P23 |
| A-1) For simplex, thread connection (ACL, 10A~80A) | P24 |
| A-2) For simplex, flange connection (ACLF, 10A~65A) | P26 |
| A-3) For simplex, flange connection (ACLF, 80A) | P28 |
| A-4) For duplex, stationary IP, thread connection (AC, 15A~80A) | P30 |
| A-5) For duplex, stationary IP, flange connection (ACF, 15A~65A) | P32 |
| A-6) For duplex, stationary IP, flange connection (ACF, 80A) | P34 |
| A-7) For duplex, rotational IP, thread connection (ACW-1/ACW-2, 25A~40A) | P36 |
| A-8) For duplex, rotational IP, thread connection (ACW-1/ACW-2, 50A~80A) | P38 |
| A-9) For duplex, rotational IP, flange connection (ACFW-1/ACFW-2, 25A~40A) | P40 |
| A-10) For duplex, rotational IP, flange connection (ACFW-1/ACFW-2, 50A~65A) | P42 |
| A-11) For duplex, rotational IP, flange connection (ACFW-1/ACFW-2, 80A) | P44 |

1. How to Read Nameplate (Nameplate Information)

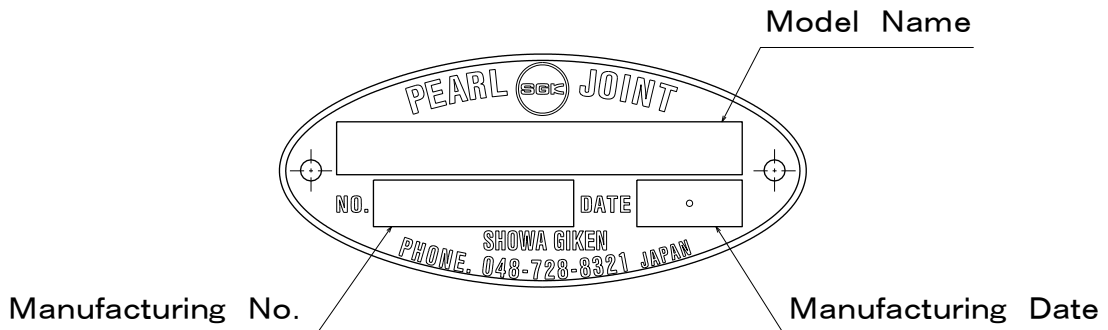

The nameplate attached to the product indicates the model name, manufacturing number, and manufacturing date.

2. For Safety

2-1) Symbols

The symbols used in this instruction manual are described below.



Indicates that failure to follow the warning message may cause bodily accidents that may result in serious or even fatal injury.



Indicates that failure to follow the caution message may cause personal injury or damage to peripheral equipment.



Indicates that failure to follow the instruction message may cause reduced product lifetime, product damage, or early leakage.



Indicates “prohibited actions”.

2-2) For safe use

1. Transport, storage, installation, piping, operation, or maintenance of this product should be carried out by an experienced expert.
2. Be sure to observe all warnings, cautions, and instructions described in each section.
3.  Never disassemble or modify this product because doing so is dangerous. We shall assume no responsibility for any malfunctions, accidents, or the results thereof involving a reassembled product after disassembly or a modified product. Also, a reassembled product after disassembly or a modified product shall not be covered by the product warranty even if the warranty period is still valid. This also applies to repairs done by yourself.
4. Confirm specifications (dimensions, materials, masses) indicated on individual product drawings before starting work. Contact our sales representative for requests for product drawings.
5. Always use the latest instruction manual. You can download the latest version from our website.

3. Product Overview

3-1) Application

A rotary joint is used for supplying fluid to or draining it from a machine rotating part called a roll, drum or cylinder, via fixed pipes.

3-2) Information indicated by model names

Information indicated by AC series model names is described below.

The product list is shown in our catalog or on our website.

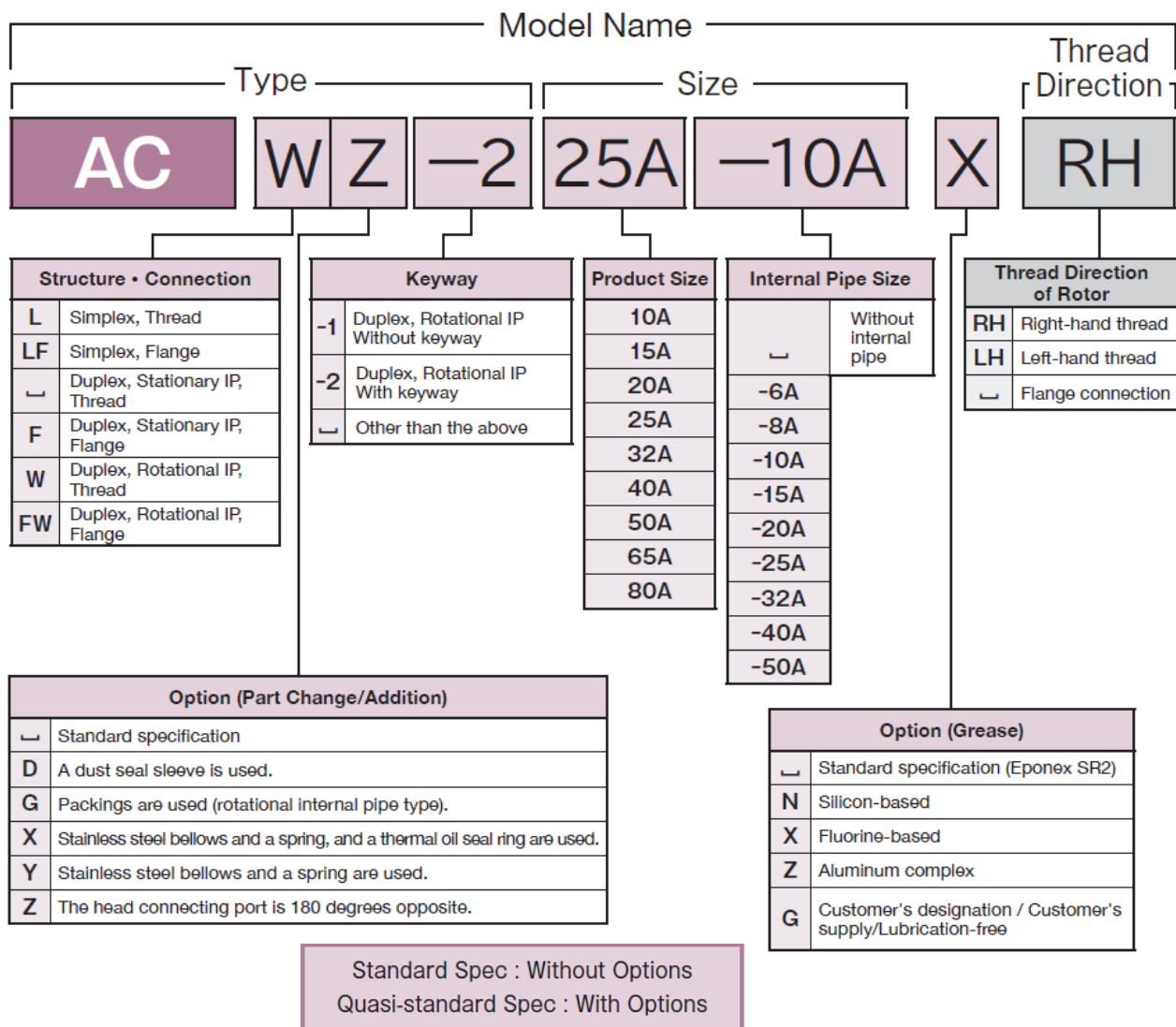

Note 1) “┌” indicates a space. A model name is indicated without spaces.

2) If option (part change/addition) code G is selected, W in a type indication is omitted.

Thus, the type indication is ACG-1, ACG-2, ACFG-1, or ACFG-2.

3) If two or more option (part change/addition) codes are selected, they are indicated in alphabetical order.

4) The selection of two or more options resulting in a long model name is indicated as type “OC****” to denote a customized product for administrative reasons.

(The asterisks (****) indicate a four-digit number allocated to each model.)

If you have any questions, contact our sales representative.

3-3) Service conditions

Service Conditions of AC Series

| Series | Fluid | Size | Max. | | |
|--------|--|---------|----------------|-------------------------------------|------------------|
| | | | Pressure (MPa) | Rotation speed (min ⁻¹) | Temperature (°C) |
| AC | Saturated Steam / Thermal Oil / Water / Oil / Air | 10A~40A | 1.47 | 300 | 180 |
| | | 50A~80A | | 150 | |

Note 1) The maximum service temperature of 180°C is a standard specification.

2) If thermal oil is used at 180°C or higher, select option (part change/addition) code X.

3) If steam is used at 180°C or higher (1.0 MPa or higher), use a product with option (part change/addition) code Y.

3-4) Precautions for use

Use this product by following the warnings and instructions described below.







WARNING

1. If flammable fluids leak and ignite, bodily accidents including serious or even fatal injury, or accidents that damage peripheral equipment may occur due to explosion or fire. Depending on the type of fluid, this product may be subject to restrictions due to national laws or local regulations.
2.  This product cannot be used for food-processing machinery. Doing so may lead to adverse health effects.



Instruction

1. Perform operation within the service conditions.
2.  Do not operate under conditions where both pressure and rotation speed are close to the max. values. Doing so significantly reduces product lifetime.
3.  This product cannot be used in temperature conditions where the product ambient temperature exceeds the upper limit of the service conditions.
4.  The product cannot be used for liquid containing solid particles (slurry) or pulverulent body. The product cannot be used for fluid that causes corrosion on it.
5.  **This product cannot be used for operation with no rotation, intermittent rotation, or low-rotation speed (a few rotations per minute).** Otherwise, fluid leakage may occur.

3-5) Product structures and materials

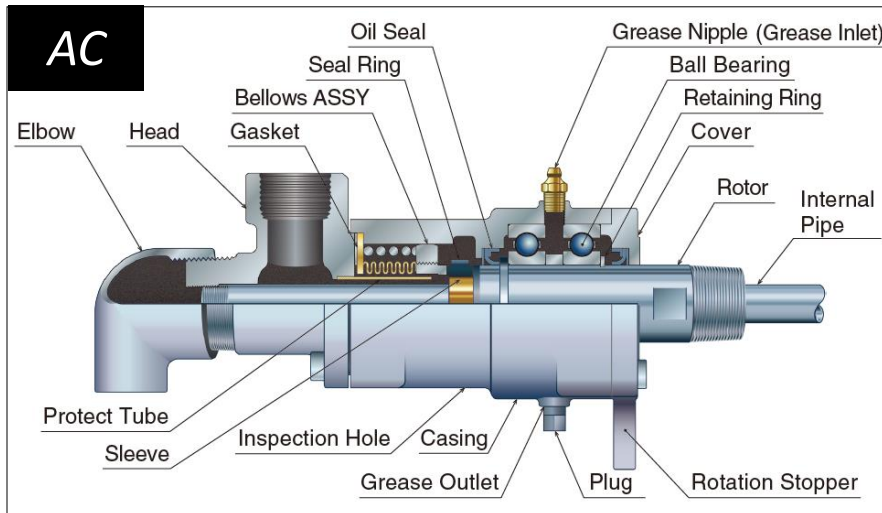

Materials of Main Components
(Standard Specification)

| Part Name | Material |
|--------------|-----------------|
| Rotor | Carbon Steel |
| Casing | Cast Iron |
| Head | Cast Iron |
| Seal Ring | Carbon |
| Sleeve | Brass |
| Bellows | Phosphor Bronze |
| Protect Tube | Brass |

Heat-resistant paint is applied to external parts.

Note) Component materials are indicated on product drawings.
Contact our sales representative for requests for product drawings.

3-6) Product dimensions

Product dimensions are shown on product drawings, in our catalog, or on our website.

3-7) Product masses

Masses of AC Series (kg)

| Type | 10A | 15A | 20A | 25A | 32A | 40A | 50A | 65A | 80A |
|----------------|-----|-----|-----|-----|------|------|------|------|------|
| ACL | 2.2 | 2.2 | 3.2 | 5.2 | 9.0 | 9.2 | 12.0 | 19.0 | 25.0 |
| ACLF | 2.4 | 2.4 | 3.4 | 5.6 | 9.6 | 9.8 | 13.5 | 20.5 | 27.0 |
| AC | - | 2.3 | 3.8 | 6.0 | 9.3 | 9.5 | 12.5 | 22.0 | 28.0 |
| ACF | - | 2.5 | 4.0 | 6.4 | - | 10.1 | 14.0 | 23.5 | 30.0 |
| ACW-1, ACW-2 | - | - | - | 6.5 | 11.3 | 11.5 | 14.0 | 25.0 | 32.0 |
| ACFW-1, ACFW-2 | - | - | - | 6.9 | - | 12.1 | 15.5 | 26.5 | 34.0 |

3-8) Accessories

1. A product installed with a flange is supplied with a gasket (copper jacket) and four sets of a stud bolt (SS400), a hex. nut (SS400), and a spring washer (SWRH) for up to 65A or six sets thereof for 80A.

Accessories (Flange Connection) (mm)

| Type | Size | Gasket | | | Stud Bolt | | | | Hex. Nut | Spring Washer |
|--------|------|------------|------------|------------|-----------|----|----|----|-----------|---------------|
| | | Outer Dia. | Inner Dia. | Thick-ness | K | L | a | b | | |
| ACLF | 10A | 24 | 16 | 3.2 | M8 | 36 | 11 | 18 | M8 type1 | M8 No.2 |
| | 15A | | | | | | | | | |
| ACF | 20A | 29 | 20 | 3.2 | M10 | 45 | 15 | 20 | M10 type1 | M10 No.2 |
| | 25A | | | | | | | | | |
| ACFW-1 | 32A | 49 | 37 | 3.2 | M10 | 48 | 15 | 20 | M10 type1 | M10 No.2 |
| | 40A | | | | | | | | | |
| ACFW-2 | 50A | 64 | 50 | 3.2 | M12 | 58 | 18 | 27 | M12 type1 | M12 No.2 |
| | 65A | | | | | | | | | |
| | 80A | 89 | 74 | 3.2 | | | | | | |

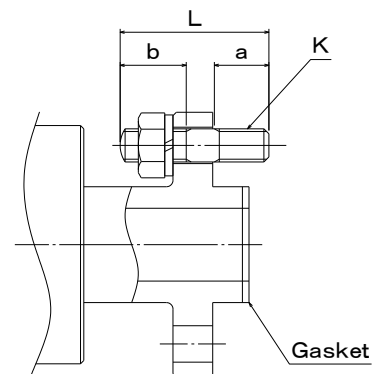

2. A duplex, stationary IP, flange connection product (ACF) is supplied with a lock nut (right-hand thread, SS400) used for securing the internal pipe.
3. A duplex, rotational IP product (ACW-1, ACW-2, ACFW-1, or ACFW-2) is supplied with a seal kit for the internal pipe.

Accessories (Duplex, Rotational IP) (mm)

| Type | Internal Pipe Size | Rotating Seal Kit | | | | | | |
|--------|--------------------|-------------------|-----------|--------|---------|--------|-----------|--------|
| | | Rotor Ring | Spring | Washer | Nut | Washer | Split Pin | O-Ring |
| ACW-1 | 8A | 36 × 25 | 34 × 40 | 36 × 4 | AN02 | AW02 | - | AS-114 |
| | 10A | | | | | | | |
| ACW-2 | 15A | 47 × 34 | 45 × 45 | 50 × 5 | AN05 | AW05 | - | AS-214 |
| | 20A | | | | | | | |
| ACFW-1 | 25A | 56 × 35 | 55 × 45 | 56 × 5 | 48 × 10 | - | 3 × 20 | AS-219 |
| ACFW-2 | 32A | 64 × 45 | 62.5 × 50 | 64 × 5 | AN08 | AW08 | - | AS-326 |
| | 40A | 71 × 45 | 71 × 50 | 71 × 5 | AN09 | AW09 | - | AS-328 |
| | 50A | 82 × 48 | 82 × 55 | 82 × 6 | AN11 | AW11 | - | AS-331 |

Note) Dimensions of the rotor ring, spring, washer, and nut (for 25A) are the “maximum outer diameter x length (thickness)”.

4. Transport and Storage

4-1) Transport

Transport this product by following the cautions and instructions described below.



CAUTION

To transport a product that weighs over 25 kg, use appropriate lifting equipment to prevent injuries.

Note) Even if the product weight is less than 25 kg, it increases to 25 kg or more when an internal pipe or a journal flange is installed to the product.



Instruction

1. **Do not subject the product to undue impact** while it is being transported. Falling down or impact causes product damage (grease nipple, seal ring, etc.) or early leakage. If the product fell down or was damaged, contact us for maintenance.
2. When transporting a product with an internal pipe, **do not secure the product so that the load is directly applied to the internal pipe**. Doing so may bend the internal pipe, hindering installation to a roll. Moreover, abnormal noise or early leakage may result after installation.

4-2) Storage

An improper storage method causes product damage or early leakage.

Store this product by following the instructions described below.



Instruction

1. Wrap the product before storing it to prevent the entry of foreign objects.
2. Store this product in a dry environment at 10°C to 40°C.
3. The storage period should be within two years. If the storage period exceeds two years, contact us for maintenance.
4. If the product is stored after use, clean and then store it under the above conditions.

5. Installation to Machinery

Product adjustment is not required before installation.

5-1) Installation procedure

Install the internal pipe and product to a roll according to the following procedure.

| Flow Passage | Internal Pipe | Type | Installation Procedure | | |
|--------------|------------------------|-----------------|--|---|---------------------------------------|
| Simplex | - | ACL ACLF | - | Install the product to a roll. | - |
| Duplex | Stationary | AC | Screw the internal pipe into the product. | Install the product to a roll. | - |
| | | ACF | Screw the internal pipe into the product and secure it with the lock nut. | | |
| | Rotational Without key | ACW-1 ACFW-1 | Install the internal pipe to a roll. | Insert the internal pipe into the product, and install the product to a roll. | Install a seal kit for internal pipe. |
| | Rotational With key | ACW-2 ACFW-2 | Insert the internal pipe into the product, and install a seal kit for internal pipe. | Install the product to a roll. | - |

Note 1) The internal pipe of ACW-1 or ACFW-1 is installed to a roll with screws, etc.

2) The installation procedure described above is applicable to general internal pipes.

The order of the procedure varies depending on the internal pipe shape.

5-2) Internal pipe installation (for duplex only)

Install an internal pipe to the product according to the following instructions.

| | |
|--------------------|--|
| Instruction | <ol style="list-style-type: none"> 1. When inserting an internal pipe into the product rotor, <u>be careful so that the pipe does not hit inner parts.</u> Failure to do so could cause inner part damage, resulting in fluid leakage. 2. When installing an internal pipe to the product, <u>be careful not to bend the pipe.</u> If it is bent, product installation to a roll may be hindered. Also, vibration or abnormal noise after installation, or early leakage may result. |
|--------------------|--|

● Duplex, stationary IP, thread connection (AC)

Screw the internal pipe taper thread into the head. For standard specification products, the thread directions of the rotor and internal pipe are the same. Depending on the customer's request, the thread directions of the rotor and internal pipe may be different from each other. Check the thread directions on the product drawings, etc. before installation.

● Duplex, stationary IP, flange connection (ACF)

Screw G thread (right-hand thread) of the internal pipe into the head, and then secure it with a supplied lock nut.

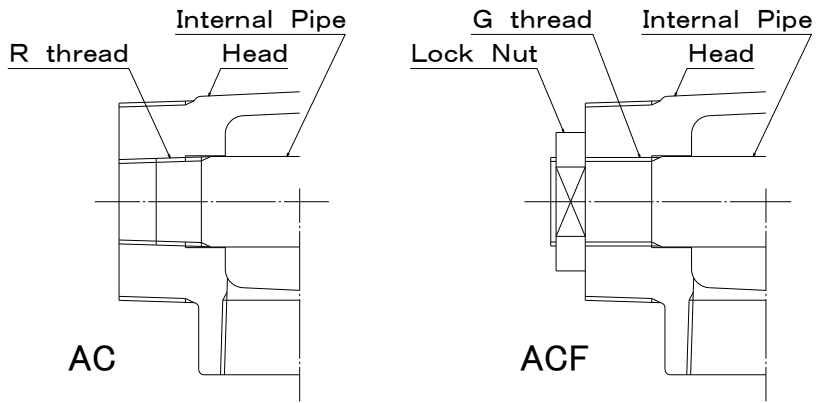

● Duplex, rotational IP (ACW-1, ACW-2, ACFW-1, ACFW-2)

After inserting the internal pipe into the product, install the supplied seal kit for internal pipe.

- 1) Check that the O-ring is installed in the inner perimeter of the rotor ring. Then apply grease to the O-ring inner perimeter.
- 2) Put the rotor ring into the internal pipe while inserting the round pin of the rotor ring into the internal pipe slit. At this point, be careful so that the O-ring is not damaged by thread created on the internal pipe.

【 Internal pipe size : 8A 10A 15A 20A 32A 40A 50A 】

- 3) Install the spring, washer and washer into the internal pipe, and secure both with the nut.

Screw the nut until the internal pipe is visible (protrudes by about 3 mm).

- 4) Bend the tab of washer for preventing looseness.

【 Internal pipe size : 25A 】

- 3) Install the spring and washer into the internal pipe, and secure both with the nut.

Screw the nut until the internal pipe is visible (protrudes by about 3 mm).

- 4) Insert the split pin into the hole on the nut outer perimeter, and then bend it in the internal pipe for preventing looseness.

(Attention) The rotor of ACW-2 or ACFW-2 has a keyway. When installing the internal pipe to the product, align the internal pipe key with the rotor keyway.

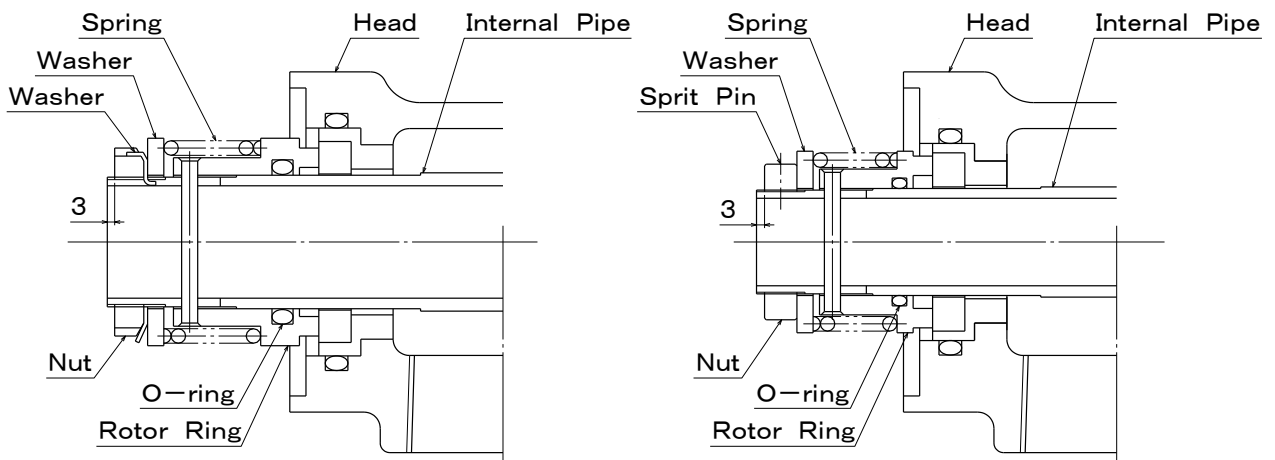

Internal pipe size
8A-50A (Except for 25A)

Internal pipe size
25A

ACW-1, ACW-2, ACFW-1, ACFW-2

5-3) Siphon pipe, Siphon elbow (for duplex, stationary IP only)

- * If the siphon pipe or siphon elbow is not included in the package or has already been installed before shipment, this step is not required.

1) Siphon pipe



Instruction

Check if the length and thread direction of the siphon pipe is appropriate in advance with drawings, etc.

1. When the siphon pipe is used in contact with the roll, contact noise may be generated and the roll may be damaged, such as contact scratches.
2. If the siphon pipe is short, it may not be as effective as expected in collecting drain in the roll.
3. If the thread direction is inappropriate, the siphon pipe may fall out of the internal pipe and into the roll due to loosening of the screw.

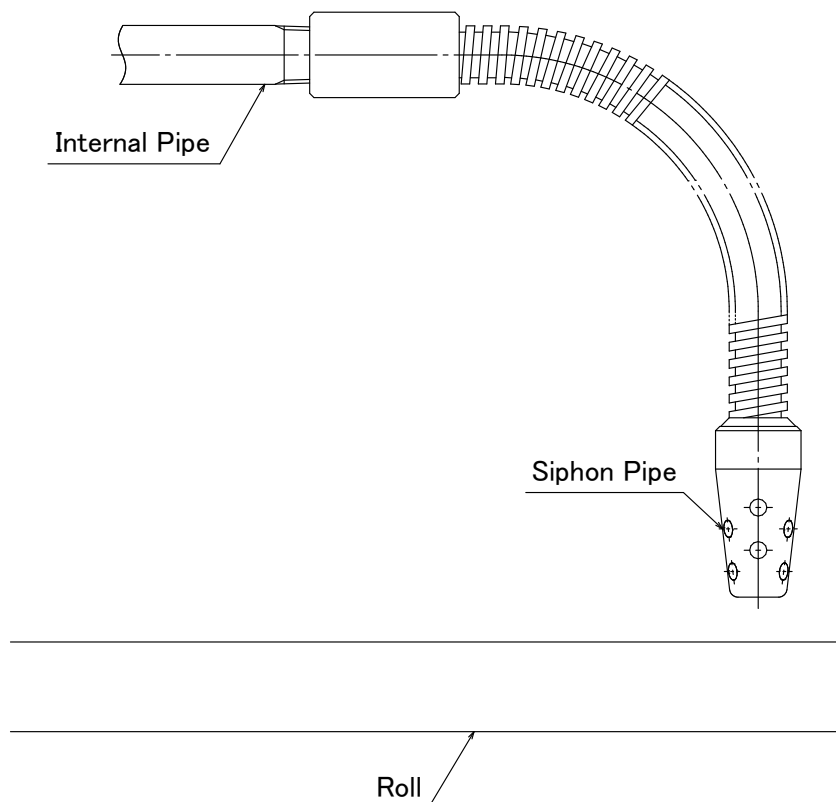

● Siphon pipe installation (AC, ACF)

Attach the siphon pipe to the taper thread section of the internal pipe. The thread direction of the internal pipe is "left-hand thread when the direction of rotation of the roll is clockwise" and "right-hand thread when it is counterclockwise" as viewed from the side from which the product is installed.

2) Siphon Elbow



CAUTION

Check in advance with a drawing or the like whether the length of the hanging pipe to be attached to the siphon elbow is appropriate.

1. If the hanging pipe is inappropriately long, the hanging pipe may contact the roll, resulting in abnormal noise, product damage, injury to workers, or damage to surrounding equipment.
2. If the hanging pipe is inappropriately short, it may not be as effective as expected in collecting drain in the roll.

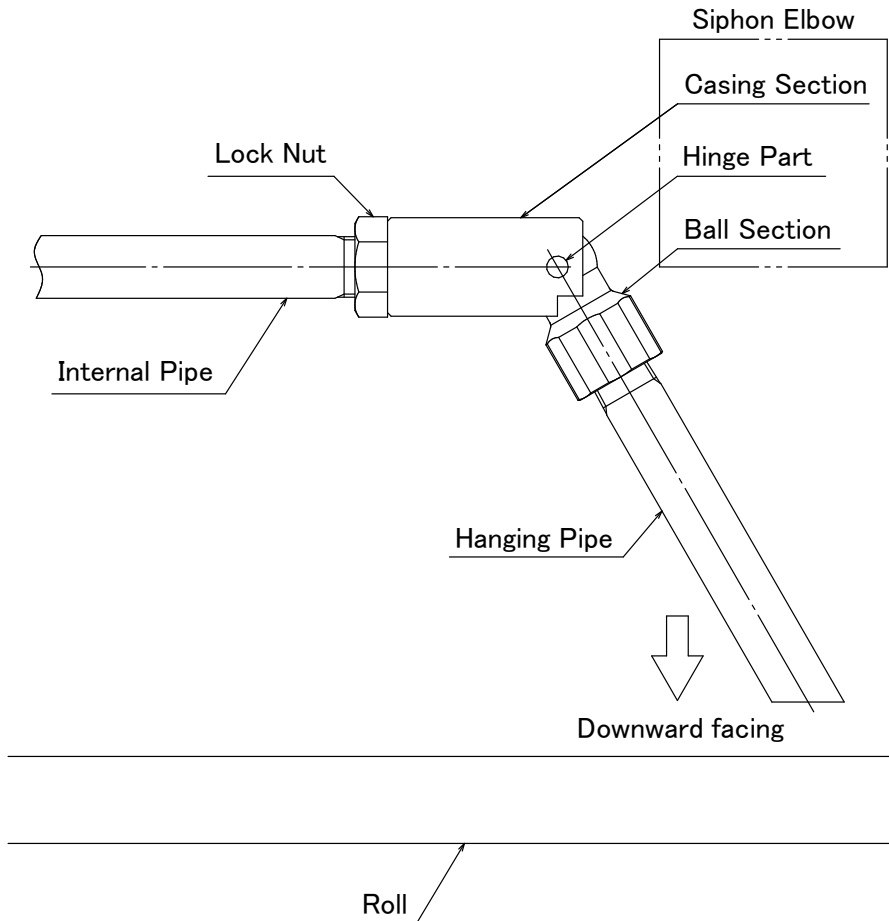

● Siphon elbow installation (AC, ACF)

The hanging pipe should be installed so that it faces downward.

1. Attach the hanging pipe to the taper thread section of the siphon elbow while holding the ball section of the siphon elbow.
2. Screw the lock nut onto the G thread section of the internal pipe. Next, screw the siphon elbow onto the internal pipe and fix it with the lock nut. Holding the ball section of the siphon elbow or hanging pipe when tightening the lock nut could damage the hinge part. Be sure to hold the casing section when tightening the lock nut.

5-4) Installing to a roll

Install the product by following the warnings, cautions, and instructions described below.



WARNING

Be sure to install the product so that an inspection hole faces downward.

Also, **do not block the hole.** This hole is used for detecting leakage at an early stage. If this hole is directed toward other directions or is blocked, leakage cannot be detected at an early stage. Moreover, leaked fluid may accumulate in a casing and ball bearings may be damaged, causing serious bodily accidents due to resulting rotation failure.



CAUTION

In order to prevent injuries, take the product weight into consideration before installing the product. Use equipment such as a crane as necessary. This work should be performed by two or more persons.



Instruction

1. **Remove any foreign objects in such flow passages as a pipe or a roll** before product installation. If the fluid contains foreign objects, install a strainer at the flow passages. Foreign objects cause early leakage.
2. If the product is installed with its center misaligned or tilted, vibration or abnormal noise may result. Moreover, the product or machine equipment may be damaged due to vibration.
3. When tightening screws or nuts, properly torque-tighten them according to the screw type or size.
4. To prevent uneven tightening, evenly tighten flange screws in a cross pattern.
5. Perform retightening after the start of use.
6.  To prevent internal pipe damage, do not hook a webbing sling to an internal pipe. Hook a webbing sling to a casing.

●Installation: taper thread

1. Wrap seal tape around the taper thread of the rotor.
2. Use the shank on the rotor to screw the product into a roll.

The 80A rotor does not have a shank for engaging a spanner. Use a pipe wrench for installation.

●Installation: flange

1. Install the supplied stud bolts to a roll.
2. Install the supplied gasket to a roll socket.
3. Insert the rotor spigot into the roll socket while checking that the stud bolts go through the rotor flange holes.
4. Set the supplied spring washers on the stud bolts, and then secure the product with the supplied nuts.

The flange of 80A is detachable. Install it to the rotor together with a split ring in advance.

● Installation: internal pipe with siphon elbow (AC, ACF)

1. Confirm that the hanging pipe drops downward approximately 60 degrees under its own weight from the hinge part of the siphon elbow.

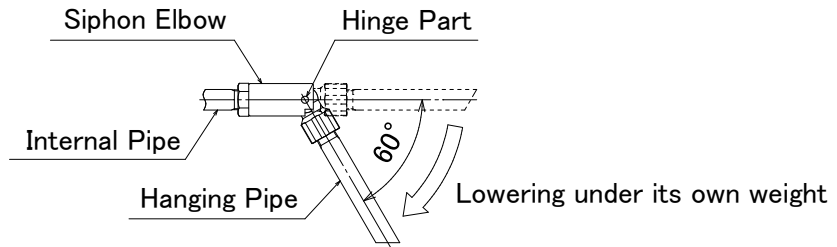

2. Rotate the product so that the hanging pipe and internal pipe are aligned and insert it into the roll.

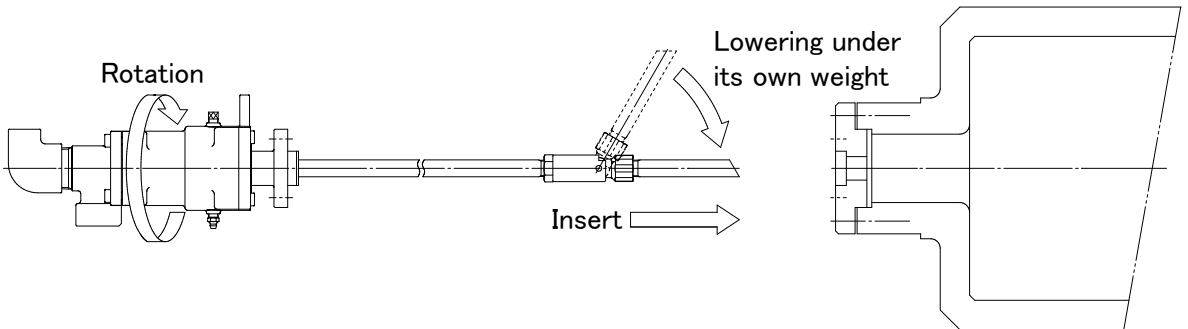

3. Rotate the product during insertion to confirm that the hanging pipe has lowered under its own weight, and then insert the product to the end.

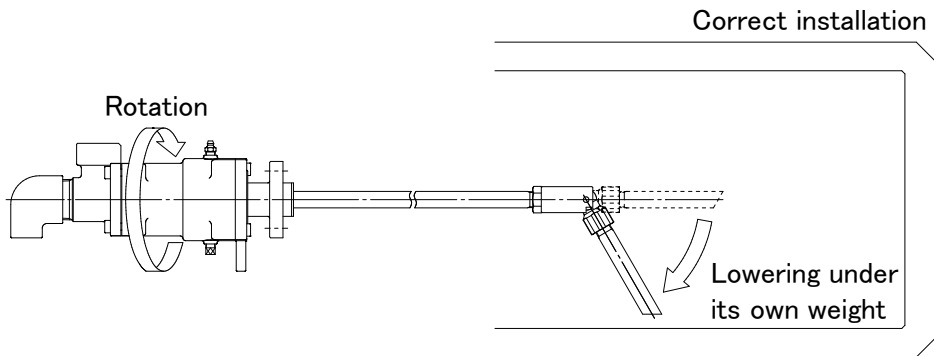

CAUTION

If step 3 is not performed properly, the hanging pipe may contact the roll depending on the depth and inner diameter of the roll, resulting in damage to the product, injury to workers, or damage to the surrounding equipment.

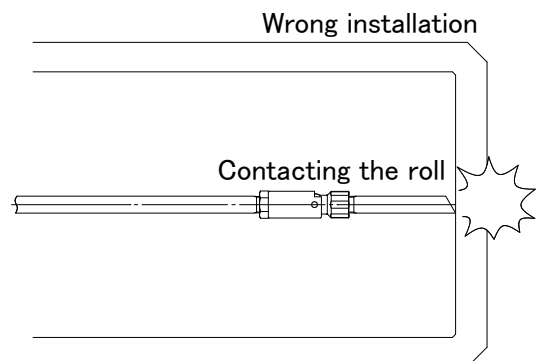

5-5) Pipe laying

Perform pipe laying work by following the warnings and instructions described below.



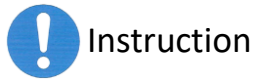

WARNING

Use a flexible metal tube suitable for characteristics of the fluid used and operating conditions (pressure, temperature). If an unsuitable flexible metal tube is used, it may be damaged, causing injury to workers or damage to peripheral equipment.



Instruction

Observe the following instructions to prevent the generation of force applied to the sides of the product, possibly causing product damage or early leakage.

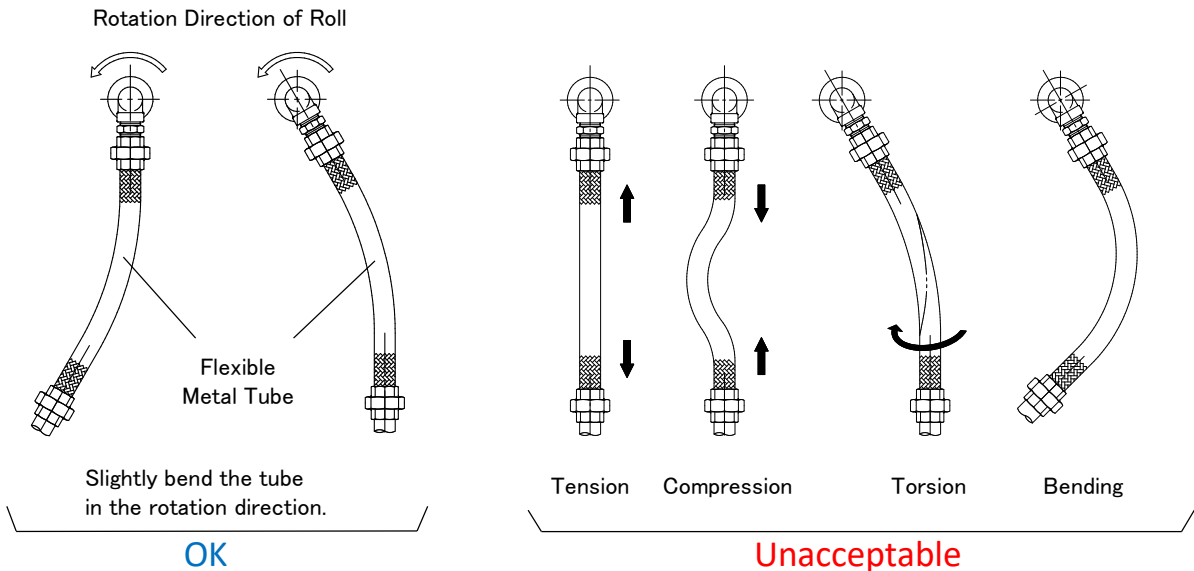

1. **Use a flexible metal tube for connection to the product.**
2.  **Steel pipes should not be used for pipe laying.**
3.  **Avoid such pipe laying where heavy items such as valves are suspended from the product.**
4. **When installing a flexible metal tube, slightly bend it in the rotation direction of roll.** (See the bottom left figure.)
5. **Carry out pipe laying work so that excessive “tension”, “compression”, “torsion”, or “bending” is not applied to a flexible metal tube.** In particular, “torsion” may significantly reduce the lifetime of the flexible metal tube. (See the bottom right figure.)
6. Use the following table as a guideline for the flexible metal tube length.



| | Flexible Metal Tube Length (Guideline) | | | | | | (mm) |
|--------|--|---------|---------|----------|-----------|-----------|------|
| Size | 10A~20A | 25A | 32A/40A | 50A | 65A | 80A | |
| Length | 300~400 | 400~500 | 600~800 | 900~1000 | 1200~1300 | 1500~1600 | |

5-6) Measures for preventing rotation

A measure for preventing casing rotation is required. Take a measure according to the following instructions.

| | |
|--|---|
|  Instruction |  Do not secure the rotation stopper to an anti-rotation plate or a round bar. Doing so can apply a load to the product, causing product damage or early leakage. |
|--|---|

Example of a measure using a round bar

(The periphery of a round bar that comes in contact with the rotation stopper must be smooth.)

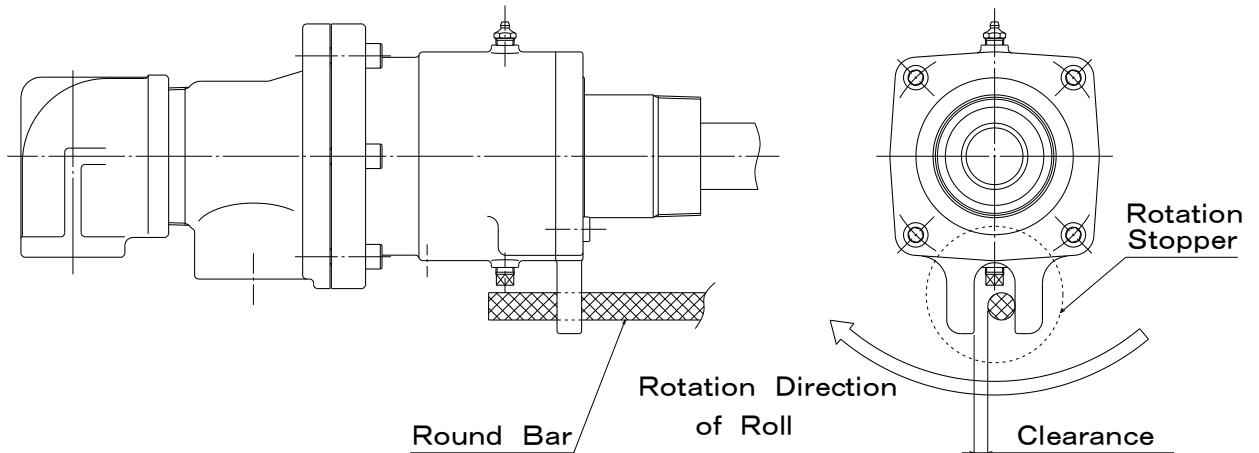

6. Removal from Machinery

Remove the product by following the warnings, cautions, and instructions described below in reverse order of the installation.



WARNING

In order to prevent bodily accidents due to residual fluid in the product or pipes, remove the product after fluid has been completely drained from the product or pipes and temperature has dropped to room temperature.



CAUTION

In order to prevent injuries, take the product weight into consideration before removing the product. Use equipment such as a crane as necessary. This work should be performed by two or more persons.



Instruction



To prevent internal pipe damage, do not hook a webbing sling to an internal pipe. Hook a webbing sling to a casing.

| Flow Passage | Internal Pipe | Type | Removal procedure | | |
|--------------|------------------------|-----------------|--|---------------------------------|--|
| Simplex | - | ACL ACLF | - | Remove the product from a roll. | - |
| Duplex | Stationary | AC | - | Remove the product from a roll. | Remove the internal pipe from the product. |
| | | ACF | | | Remove the lock nut, and then remove the internal pipe from the product. |
| | Rotational Without key | ACW-1 ACFW-1 | Remove the seal kit for internal pipe. | Remove the product from a roll. | Remove the internal pipe from a roll. |
| | Rotational With key | ACW-2 ACFW-2 | - | Remove the product from a roll. | Remove the seal kit for internal pipe, and then remove the internal pipe from the product. |

Note) The removal procedure described above is applicable to general internal pipes.

7. Operation

7-1) Operation

Perform operation by following the warnings, cautions, and instructions described below.



WARNING

Immediately stop operation if fluid leakage is detected during operation. If operation is continued with fluid leakage not being repaired, serious accidents including bodily accidents may result.



CAUTION



During rotation or high-temperature/pressure fluid flow, keep well away from the product to prevent injuries or burns. Do not directly touch rotating or hot parts during operation.



Instruction

1. When starting operation, check for abnormal rotation (center runout, abnormal noise, etc.) or fluid leakage from the product while gradually increasing fluid pressure and roll rotational velocity.
2. If operation is continued under a center runout condition, product damage or fluid leakage may result.
3. The occurrence of surging or water hammer can cause product damage or fluid leakage. Avoid such occurrence.
4.  **Do not perform dry operation (operation without fluid flow) for a long time.** The product lifetime becomes shortened.
5. If the fluid is air, add oil mist to the air.

7-2) Operation shutdown

Follow the following instructions during operation shutdown.



Instruction

1. **If the product is left as is for a long time during operation shutdown, rust may occur, causing fluid leakage after operation restart.** Clean flow passages for the product, pipes, and roll before restarting operation.
2. **If water is used as the fluid, take a measure to prevent water from freezing in the product.** Freezing may cause product damage, resulting in fluid leakage after operation restart.
3.  Do not put your hand on or ride on the product during equipment maintenance. Doing so may cause product damage or fluid leakage after operation restart.

8. Inspection and Maintenance

8-1) Daily inspection



Perform inspection according to the following instructions.

| | |
|---|---|
|  Instruction | <ol style="list-style-type: none"> 1. Visually check pipe connections, product connections, and the product for fluid leakage. If leakage is detected, repair the product or replace it with a new one. 2. When replacing, use the same type of product with the same size. |
|---|---|

8-2) Greasing

Periodic greasing (refilling) of ball bearings is required.

Carry out greasing according to the following instructions.

| | |
|---|---|
|  Instruction | <ol style="list-style-type: none"> 1. Remove the grease outlet plug and fill the grease through the grease nipple (grease inlet). Continue to fill until new grease comes out from the grease outlet. 2. <u>If the grease is filled without removing the plug, parts inside the product may be damaged by the grease pressure, causing fluid leakage.</u> 3.  Use the same grease as the one filled in the product before shipment. Do not use grease mixed with other ones. Doing so may reduce the lubricating effect. 4. Carry out greasing with reference to the frequency and amount (guideline) shown in the following table. Failure to carry out greasing can reduce the lubricating performance of the grease, causing the reduction in the ball bearing lifetime. |
|---|---|

< Grease filled in the product before shipment >

1. Daphne Eponex SR2 (Idemitsu Kosan) is filled in standard specification products.
2. Grease different from the standard specification is filled if a model name includes an option (grease) code. Check the grease brand before greasing.

Greasing Frequency
(Guideline)

| Fluid Temperature (°C) | Greasing Frequency |
|---------------------------|-----------------------|
| 0~130 | Every three months |
| 130~150 | Monthly |
| 150~180 | Weekly |

Grease Amount
(Guideline) (cm³)

| Size | First Time | Refill |
|------|------------|--------|
| 10A | 20 | 10~12 |
| 15A | 20 | 10~12 |
| 20A | 30 | 15~18 |
| 25A | 45 | 23~27 |
| 32A | 65 | 33~39 |
| 40A | 65 | 33~39 |
| 50A | 70 | 35~42 |
| 65A | 175 | 88~105 |
| 80A | 175 | 88~105 |

8-3) Repair and replacement of consumables

The ball bearings and the seal face of the seal ring become worn over the course of operation time. O-rings also deteriorate. Moreover, if the internal pipe rotates in the product, bearings that support the pipe also become worn. Then such malfunctions as fluid leakage may occur. However, the product can be reused by repairing or replacing worn or deteriorated parts.

Contact us for repair or parts replacement. We carry it out according to our repair program. Depending on the products, expenses for purchasing new products may be lower than repair expenses. Consult with us when requesting repair or replacement.

< When carrying out repair or replacement of consumables by yourself >

- Repair or replacement should be carried out by an experienced expert.
- Perform work according to “A. Appendix – How to Repair or Replace Consumables”.
- Use our genuine parts as replacement parts.
Contact our sales representative to request genuine parts.
- Properly dispose of waste resulting from work according to national laws or local government regulations or ordinances.

(Attention)

If you carry out repair or replacement, we shall assume no responsibility for any product malfunctions, equipment malfunctions or accidents resulting from such product or the results thereof. Also, the product shall not be covered by the product warranty even if the warranty period is still valid.

9. Troubleshooting

This section describes the possible causes of and countermeasures against malfunctions.
If a problem persists, contact our sales representative for assistance.

| Malfunctions | Causes | Countermeasures |
|---|--|---|
| Fluid is leaking from the inspection hole. | A load is applied to the product due to an improper method of pipe laying. | Review the pipe laying method. |
| | The seal ring is damaged. The seal ring lifetime has been reached. The rotor seal face is damaged. The seal face of the bellows ASSY is damaged. The bellows have cracks. | Contact us for repair. |
| | The fluid contains foreign objects. | Clean the inside of the product, pipes, and roll. Install a strainer. |
| | A load is applied to the product due to improper countermeasures for preventing rotation. | Review the countermeasure for preventing rotation. |
| | Operation is performed without rotation, or operation occasionally ceases during the operation cycle. | Consult with us. |
| | Operation is performed at low-rotation speed (a few rotations per minute). | Consult with us. |
| | Improper product selection. | Consult with us. |
| The product has center runoff. (It is vibrating.) | The rotation axes of a roll and the product are misaligned with each other. <Flange connection type> The shaft end socket of a roll is offset from the roll rotation axis. <Thread connection type> The shaft end screw hole of a roll is offset from the roll rotation axis. | - |
| | The rotation axes of a roll and the product are inclined from each other. <Flange connection type> The shaft end socket of a roll is offset from the roll rotation axis. Uneven tightening of fixing screws. <Thread connection type> The center lines of screw holes for fixing the product are inclined from the roll rotation axis. The product is screwed in diagonally. | - |
| Noise occurs. | The internal pipe bends and comes in contact with the inner perimeter of the product rotor or that of the roll shaft. | Straighten the bent internal pipe. |
| | The internal pipe bent by its weight comes in contact with the inner perimeter of the product rotor or that of the roll shaft. | Consult with us. |
| | A load is applied to the product due to an improper method of pipe laying. | Review the pipe laying method. |
| | Ball bearings are damaged. | Contact us for repair. |
| The rotor does not rotate. | A ball bearing does not rotate. | Contact us for repair. |

10. Disposal

When disposing of packaging materials or products, properly dispose of them according to national laws or local government regulations or ordinances.

11. Product Warranty

If a malfunction occurs during the warranty period, contact us or the distributor and send the product to us. Be sure to carefully pack the product for protection before sending it. After receiving the product, we will confirm the malfunction. If the malfunction was clearly caused by the materials of product components or the manufacturing method, we will repair the product in question or replace it with a new one free of charge.

Product Warranty Provision

1. Warranty period

<New products>

One (1) year and six (6) months after shipment (from the manufacturing date) or one (1) year after installation, whichever comes first.

<Repaired products>

Six (6) months after shipment (from the manufacturing date).

2. We charge a fee for repairs in any of the following cases.

- ① Failure after the warranty period has expired
- ② Failure caused by use of the product deviating from the service conditions
- ③ Failure caused by misuse
(improper storage, installation, pipe laying, operation or maintenance, etc.)
- ④ Failure caused by fluid contaminants or foreign objects in the fluid
- ⑤ Failure caused by relocation, transport, or falling of the product after delivery
- ⑥ Failure caused by disassembly, repair, or modification done by personnel other than our service personnel
- ⑦ Failure of the product attributed to using materials or according to standards specified by the customer
- ⑧ Failure of the product attributed to using materials provided by the customer
- ⑨ Failure caused due to unavoidable acts of nature such as fires or other natural disasters

3. Scope of responsibility

Our responsibility shall be limited to repairs, replacements, or transport expenses covered by this product warranty provision. Expenses or damages caused by said failures above shall not be covered.

4. Applicable regions

This product warranty provision shall be applicable to products installed in Japan.

Contact our sales representative if you install and use our products outside Japan.

5. Another agreement

If another product warranty agreement is made separately with us and clearly states that said agreement shall have priority over this product warranty provision, this provision shall not be applicable.

6. This product warranty provision shall not restrict the customer's legal rights.

PEARL  JOINT
株式会社 昭和技研工業
SHOWA GIKEN INDUSTRIAL CO., LTD.

URL <https://www.sgk-p.co.jp>



| | |
|---------------------|---|
| Export Department | Phone : +81-3-3598-1400 Fax. : +81-3-3598-2700 E-mail : sgk-tk@sgk-p.co.jp |
| Headquarters | 7-24, Nishi-Kobari, Ina-Machi, Saitama, 362-0811 Japan Phone : +81-48-728-9460 Fax. : +81-48-728-9461 |
| Tokyo Sales Office | 2-64-11, Akabane, Kita-ku, Tokyo, 115-0045 Japan Phone : +81-3-3598-1400 Fax. : +81-3-3598-2700 |
| Osaka Sales Office | 2-9-7, Toyosaki, Kita-ku, Osaka, 531-0072 Japan Phone : +81-6-6371-8341 Fax. +81-6-6371-6283 |
| Nagoya Sales Office | 41-1, Higashi-Ozone-cho, Higashi-ku, Nagoya, 461-0022 Japan Phone : +81-52-938-8825 Fax. : +81-52-938-6423 |

A. Appendix – How to Repair or Replace Consumables

A-1) For simplex, thread connection (ACL, 10A~80A)

An explanation is given below with reference to ACL 25A (figure shown below).

Although there are size differences indicated below with asterisks (*), the same workflow is applied.

* 10A, 15A, and 20A do not have protect tube ⑬.

* Oil seals ⑥ on the bellows side of 50A, 65A, and 80A are O-rings.

* The length and number of cap screws ⑭ on the rotor side are different from those on the head side.

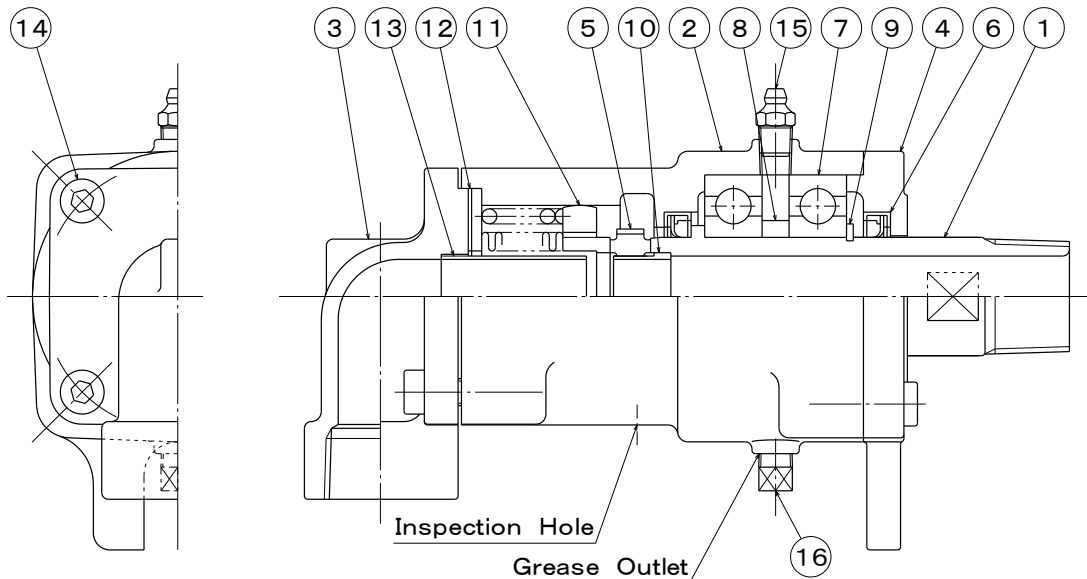

- ①Rotor ②Casing ③Head ④Cover ⑤Seal Ring ⑥Oil Seal ⑦Ball Bearing ⑧Spacer
⑨Retaining Ring ⑩Sleeve ⑪Bellows ASSY ⑫Gasket ⑬Protect Tube ⑭Cap Screw
⑮Grease Nipple ⑯Square Head Plug

< Disassembly >

Carefully disassemble the product so that each part is not damaged. In particular, be careful not to damage the seal faces of rotor ①, seal ring ⑤, and bellows ASSY ⑪.

- 1) Disconnect all pipes, etc. connected to the product.
- 2) Remove grease nipple ⑮ and square head plug ⑯.
- 3) Remove cap screws ⑭ and remove head ③ from casing ②.
- 4) Pull out gasket ⑫, bellows ASSY ⑪, and seal ring ⑤ from casing ②.
- 5) Remove cap screws ⑭ on the cover ④ side, and then remove cover ④ from casing ②.
- 6) Pull out the assembly consisting of rotor ①, ball bearings ⑦, spacer ⑧, and retaining ring ⑨ (hereinafter called the rotor assembly) from casing ②.
- 7) Remove retaining ring ⑨ from rotor ①, and then remove ball bearings ⑦ and spacer ⑧.
- 8) Remove oil seals ⑥ from casing ② and cover ④.

< Inspection >

Clean each part and check for damage. In particular, check the degree of wear and damage on the seal faces of rotor ①, seal ring ⑤, and bellows ASSY ⑪.

< Repair and parts replacement >

- 1) Rotor ①, seal ring ⑤, and bellows ASSY ⑪ may be reused by lapping their seal faces in case of minor damage.
- 2) Remove sleeve ⑩ before lapping the seal face of rotor ①. As sleeve ⑩ is deformed when removed, it cannot be reused. After lapping the seal face, prepare a new sleeve ⑩ and press-fit it in rotor ① so that no eccentricity exists.
- 3) Replace oil seals ⑥ and gasket ⑫ with new ones regardless of their conditions.
- 4) If repair or reuse of parts is impossible, replace them with our new genuine parts. Contact our sales representative to request genuine parts.

< Assembly >

Assemble the product in the reverse order of disassembly.

Carefully assemble the product so that each part is not damaged. In particular, be careful not to damage the seal faces. If dust adheres to the seal face, wipe it off with thinner.

- 1) Install oil seals ⑥ to casing ② and cover ④.
- 2) Insert ball bearing ⑦, spacer ⑧, and ball bearing ⑦ to rotor ① in order, and then install retaining rings ⑨.
- 3) Install the rotor assembly assembled in step 2) to casing ②.
- 4) Install cover ④ to casing ②, and evenly tighten cap screws ⑭ in a cross pattern to secure cover ④.
- 5) Install seal ring ⑤, bellows ASSY ⑪, and gasket ⑫ to casing ②.
- 6) Install head ③ to casing ②, and evenly tighten cap screws ⑭ in a cross pattern to secure head ③.
- 7) Check that rotor ① smoothly rotates.
- 8) Install grease nipple ⑮ and fill the grease through it. Continue to fill until new grease comes out from the grease outlet. After greasing, attach square head plug ⑯.

A-2) For simplex, flange connection (ACLF, 10A~65A)

An explanation is given below with reference to ACF 25A (figure shown below).

Although there are size differences indicated below with asterisks (*), the same workflow is applied.

* 10A, 15A, and 20A do not have protect tube ⑭.

* Oil seals ⑦ on the bellows side of 50A and 65A are O-rings.

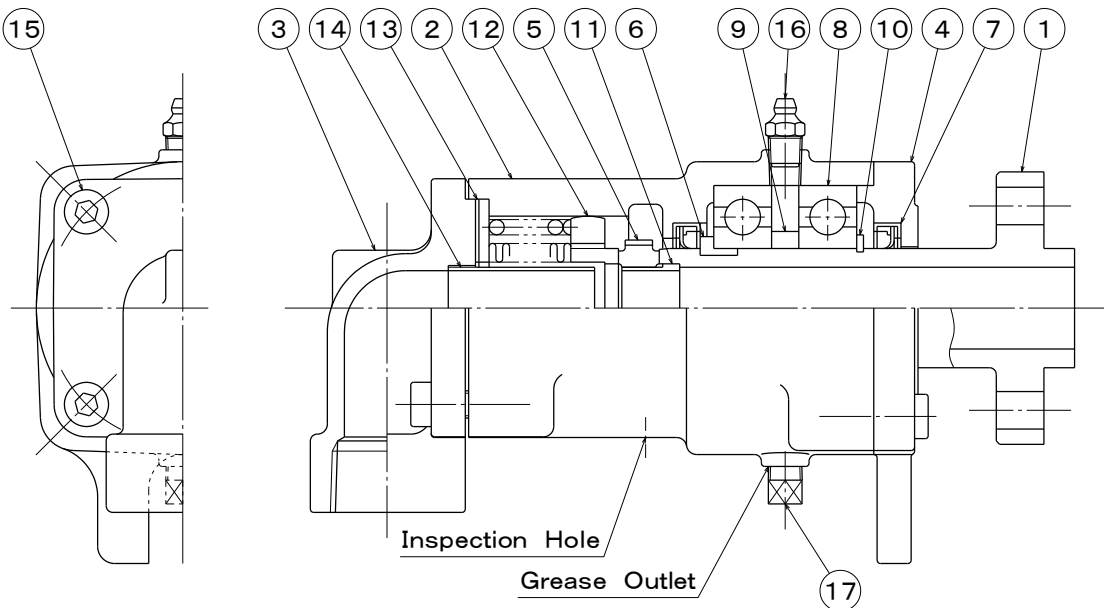

- ①Rotor ②Casing ③Head ④Cover ⑤Seal Ring ⑥Thrust collar ⑦Oil Seal ⑧Ball Bearing
⑨Spacer ⑩Retaining Ring ⑪Sleeve ⑫Bellows ASSY ⑬Gasket ⑭Protect Tube ⑮Cap Screw
⑯Grease Nipple ⑰Square Head Plug

< Disassembly >

Carefully disassemble the product so that each part is not damaged. In particular, be careful not to damage the seal faces of rotor ①, seal ring ⑤, and bellows ASSY ⑫.

- 1) Disconnect all pipes, etc. connected to the product.
- 2) Remove grease nipple ⑯ and square head plug ⑰.
- 3) Remove cap screws ⑮ and remove head ③ from casing ②.
- 4) Pull out gasket ⑬, bellows ASSY ⑫, and seal ring ⑤ from casing ②.
- 5) Remove cap screws ⑮ on the cover ④ side, and then remove the assembly consisting of rotor ①, thrust collar ⑥, ball bearings ⑧, spacer ⑨, and retaining ring ⑩ (hereinafter called the rotor assembly) from casing ②.
- 6) Remove retaining ring ⑩ from rotor ①, move ball bearings ⑧ and spacer ⑨ to the flange side, and then remove thrust collar ⑥ from rotor ①.
- 7) Remove ball bearings ⑧ and spacer ⑨ from rotor ①. Then pull out retaining ring ⑩ and cover ④ from rotor ①.
- 8) Remove oil seals ⑦ from casing ② and cover ④.

< Inspection >

Clean each part and check for damage. In particular, check the degree of wear and damage on the seal faces of rotor ①, seal ring ⑤, and bellows ASSY ⑫.

< Repair and parts replacement >

- 1) Rotor ①, seal ring ⑤, and bellows ASSY ⑫ may be reused by lapping their seal faces in case of minor damage.
- 2) Remove sleeve ⑪ before lapping the seal face of rotor ①. As sleeve ⑪ is deformed when removed, it cannot be reused. After lapping the seal face, prepare a new sleeve ⑪ and press-fit it in rotor ① so that no eccentricity exists.
- 3) Replace oil seals ⑦ and gasket ⑬ with new ones regardless of their conditions.
- 4) If repair or reuse of parts is impossible, replace them with our new genuine parts. Contact our sales representative to request genuine parts.

< Assembly >

Assemble the product in the reverse order of disassembly.

Carefully assemble the product so that each part is not damaged. In particular, be careful not to damage the seal faces. If dust adheres to the seal face, wipe it off with thinner.

- 1) Install oil seals ⑦ to casing ② and cover ④.
- 2) Put cover ④ through rotor ① and move the cover to the flange of rotor ①.
- 3) Put retaining ring ⑩ through rotor ① and move the retaining ring to the vicinity of cover ④.
- 4) Insert ball bearing ⑧, spacer ⑨, and ball bearing ⑧ to rotor ① in order, and then install thrust collar ⑥ to rotor ①. Then move ball bearing ⑧ and spacer ⑨ to the thrust collar ⑥ side, and install retaining ring ⑩.
- 5) Install the rotor assembly assembled in step 4) to casing ②.
- 6) Install cover ④ to casing ②, and evenly tighten cap screws ⑮ in a cross pattern to secure cover ④ to casing ②.
- 7) Install seal ring ⑤, bellows ASSY ⑫, and gasket ⑬ to casing ②.
- 8) Evenly tighten cap screws ⑮ in a cross pattern to secure head ③ to casing ②.
- 9) Check that rotor ① smoothly rotates.
- 10) Install grease nipple ⑯ and fill the grease through it. Continue to fill until new grease comes out from the grease outlet. After greasing, attach square head plug ⑰.

A-3) For simplex, flange connection (ACLF, 80A)

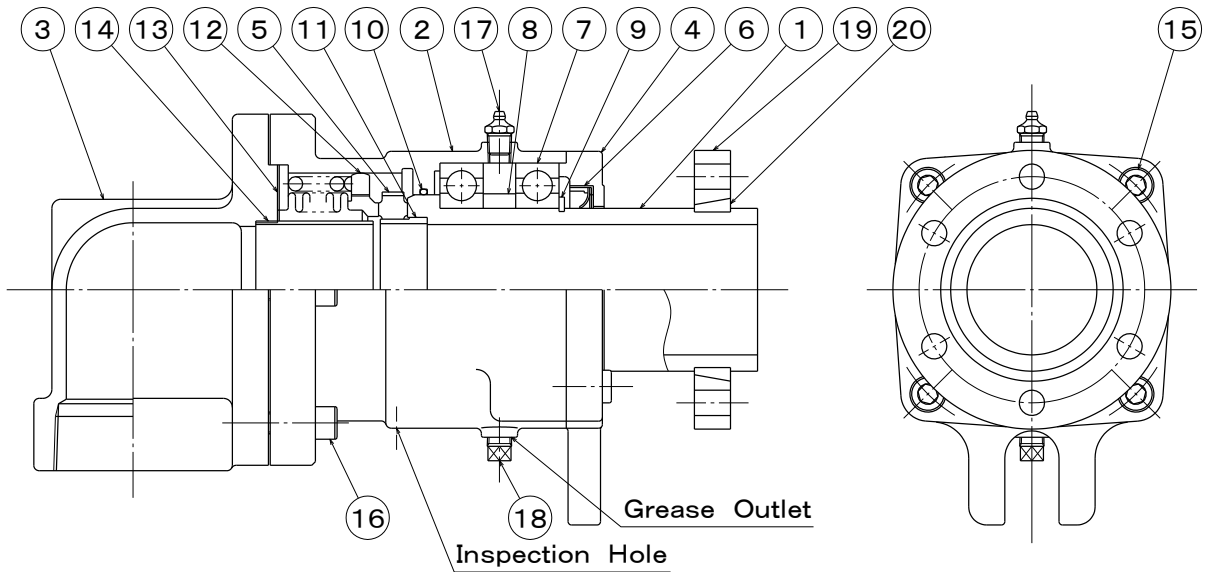

- ①Rotor ②Casing ③Head ④Cover ⑤Seal Ring ⑥Oil Seal ⑦Ball Bearing ⑧Spacer
 ⑨Retaining Ring ⑩Oil Seal (O-ring) ⑪Sleeve ⑫Bellows ASSY ⑬Gasket ⑭Protect Tube
 ⑮Cap Screw ⑯Cap Screw ⑰Grease Nipple ⑱Square Head Plug ⑲Rotor Flange ⑳Split Ring

< Disassembly >

Carefully disassemble the product so that each part is not damaged. In particular, be careful not to damage the seal faces of rotor ①, seal ring ⑤, and bellows ASSY ⑫.

- 1) Disconnect all pipes, etc. connected to the product.
- 2) Remove grease nipple ⑰ and square head plug ⑱.
- 3) Move rotor flange ⑲ to the casing ② side and remove split ring ⑳. Then pull out rotor flange ⑲ from rotor ①.
- 4) Remove cap screws ⑯ and remove head ③ from casing ②.
- 5) Pull out gasket ⑬, bellows ASSY ⑫, and seal ring ⑤ from casing ②.
- 6) Remove cap screws ⑮, and then remove cover ④ from casing ②.
- 7) Pull out the assembly consisting of rotor ①, ball bearings ⑦, spacer ⑧, and retaining ring ⑨ (hereinafter called the rotor assembly) from casing ②.
- 8) Remove retaining ring ⑨ from rotor ①, and then remove ball bearings ⑦ and spacer ⑧.
- 9) Remove oil seal (O-ring) ⑩ from casing ② and oil seal ⑥ from cover ④.

< Inspection >

Clean each part and check for damage. In particular, check the degree of wear and damage on the seal faces of rotor ①, seal ring ⑤, and bellows ASSY ⑫.

< Repair and parts replacement >

- 1) Rotor ①, seal ring ⑤, and bellows ASSY ⑫ may be reused by lapping their seal faces in case of minor damage.
- 2) Remove sleeve ⑪ before lapping the seal face of rotor ①. As sleeve ⑪ is deformed when removed, it cannot be reused. After lapping the seal face, prepare a new sleeve ⑪ and press-fit it in rotor ① so that no eccentricity exists.
- 3) Replace oil seal ⑥, oil seal (O-ring) ⑩, and gasket ⑬ with new ones regardless of their conditions.
- 4) If repair or reuse of parts is impossible, replace them with our new genuine parts. Contact our sales representative to request genuine parts.

< Assembly >

Assemble the product in the reverse order of disassembly.

Carefully assemble the product so that each part is not damaged. In particular, be careful not to damage the seal faces. If dust adheres to the seal face, wipe it off with thinner.

- 1) Install oil seal (O-ring) ⑩ to casing ② and oil seal ⑥ to cover ④.
- 2) Insert ball bearing ⑦, spacer ⑧, and ball bearing ⑦ to rotor ① in order, and then install retaining rings ⑨.
- 3) Install the rotor assembly assembled in step 2) to casing ②.
- 4) Install cover ④ to casing ②, and evenly tighten cap screws ⑮ in a cross pattern to secure cover ④.
- 5) Install seal ring ⑤, bellows ASSY ⑫, and gasket ⑬ to casing ②.
- 6) Install head ③ to casing ②, and evenly tighten cap screws ⑯ in a cross pattern to secure head ③.
- 7) Check that rotor ① smoothly rotates.
- 8) Insert rotor flange ⑰ into rotor ① and install split ring ⑳. Then move rotor flange ⑰ to the split ring ㉑ side.
- 9) Install grease nipple ⑰ and fill the grease through it. Continue to fill until new grease comes out from the grease outlet. After greasing, attach square head plug ⑱.

A-4) For duplex, stationary IP, thread connection (AC, 15A~80A)

An explanation is given below with reference to AC 25A (figure shown below).

Although there are size differences indicated below with asterisks (*), the same workflow is applied.

* 15A and 20A do not have protect tube ⑬.

* Oil seals ⑥ on the bellows side of 50A, 65A, and 80A are O-rings.

* The length and number of cap screws ⑮ on the rotor side are different from those on the head side.

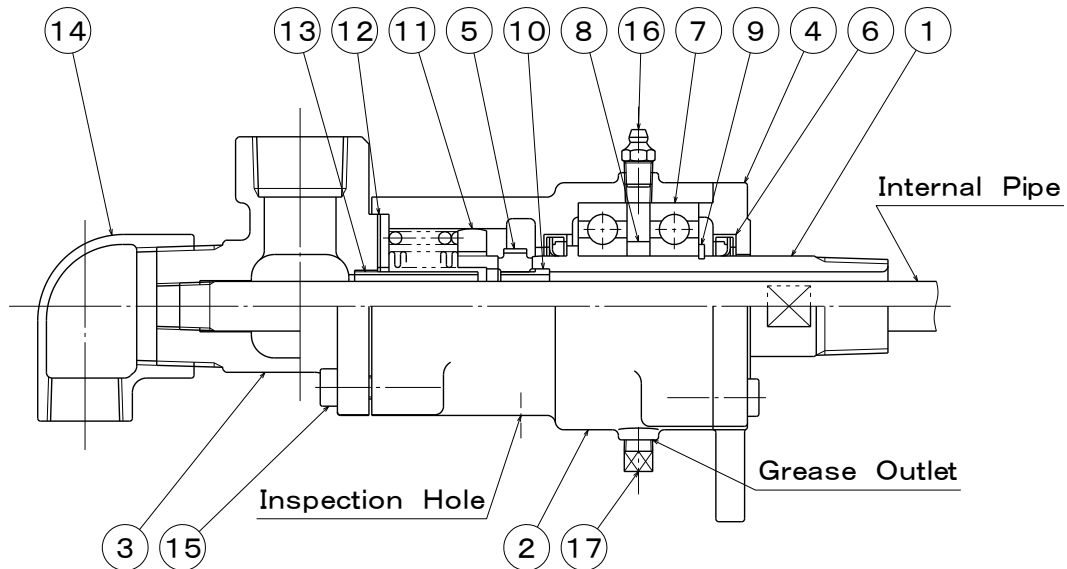

- ①Rotor ②Casing ③Head ④Cover ⑤Seal Ring ⑥Oil Seal ⑦Ball Bearing ⑧Spacer
⑨Retaining Ring ⑩Sleeve ⑪Bellows ASSY ⑫Gasket ⑬Protect Tube ⑭Elbow
⑮Cap Screw ⑯Grease Nipple ⑰Square Head Plug

< Disassembly >

Carefully disassemble the product so that each part is not damaged. In particular, be careful not to damage the seal faces of rotor ①, seal ring ⑤, and bellows ASSY ⑪.

- 1) Disconnect all pipes, etc. connected to the product.
- 2) Remove grease nipple ⑯ and square head plug ⑰.
- 3) Remove elbow ⑭ from head ③.
- 4) Remove the internal pipe.
- 5) Remove cap screws ⑮ and remove head ③ from casing ②.
- 6) Pull out gasket ⑫, bellows ASSY ⑪, and seal ring ⑤ from casing ②.
- 7) Remove cap screws ⑮ on the cover ④ side, and then remove cover ④ from casing ②.
- 8) Pull out the assembly consisting of rotor ①, ball bearings ⑦, spacer ⑧, and retaining ring ⑨ (hereinafter called the rotor assembly) from casing ②.
- 9) Remove retaining ring ⑨ from rotor ①, and then remove ball bearings ⑦ and spacer ⑧.
- 10) Remove oil seals ⑥ from casing ② and cover ④.

< Inspection >

Clean each part and check for damage. In particular, check the degree of wear and damage on the seal faces of rotor ①, seal ring ⑤, and bellows ASSY ⑪.

< Repair and parts replacement >

- 1) Rotor ①, seal ring ⑤, and bellows ASSY ⑪ may be reused by lapping their seal faces in case of minor damage.
- 2) Remove sleeve ⑩ before lapping the seal face of rotor ①. As sleeve ⑩ is deformed when removed, it cannot be reused. After lapping the seal face, prepare a new sleeve ⑩ and press-fit it in rotor ① so that no eccentricity exists.
- 3) Replace oil seals ⑥ and gasket ⑫ with new ones regardless of their conditions.
- 4) If repair or reuse of parts is impossible, replace them with our new genuine parts. Contact our sales representative to request genuine parts.

< Assembly >

Assemble the product in the reverse order of disassembly.

Carefully assemble the product so that each part is not damaged. In particular, be careful not to damage the seal faces. If dust adheres to the seal face, wipe it off with thinner.

- 1) Install oil seals ⑥ to casing ② and cover ④.
- 2) Insert ball bearing ⑦, spacer ⑧, and ball bearing ⑦ to rotor ① in order, and then install retaining rings ⑨.
- 3) Install the rotor assembly assembled in step 2) to casing ②.
- 4) Install cover ④ to casing ②, and evenly tighten cap screws ⑮ in a cross pattern to secure cover ④.
- 5) Install seal ring ⑤, bellows ASSY ⑪, and gasket ⑫ to casing ②.
- 6) Install head ③ to casing ②, and evenly tighten cap screws ⑮ in a cross pattern to secure head ③.
- 7) Check that rotor ① smoothly rotates.
- 8) Install grease nipple ⑯ and fill the grease through it. Continue to fill until new grease comes out from the grease outlet. After greasing, attach square head plug ⑰.
- 9) Install the internal pipe.
- 10) Wrap seal tape around the taper thread of head ③, and then install elbow ⑭.

A-5) For duplex, stationary IP, flange connection (ACF, 15A~65A)

An explanation is given below with reference to ACF 25A (figure shown below).

Although there are size differences indicated below with asterisks (*), the same workflow is applied.

* 15A and 20A do not have protect tube ⑭.

* Oil seals ⑦ on the bellows side of 50A and 65A are O-rings.

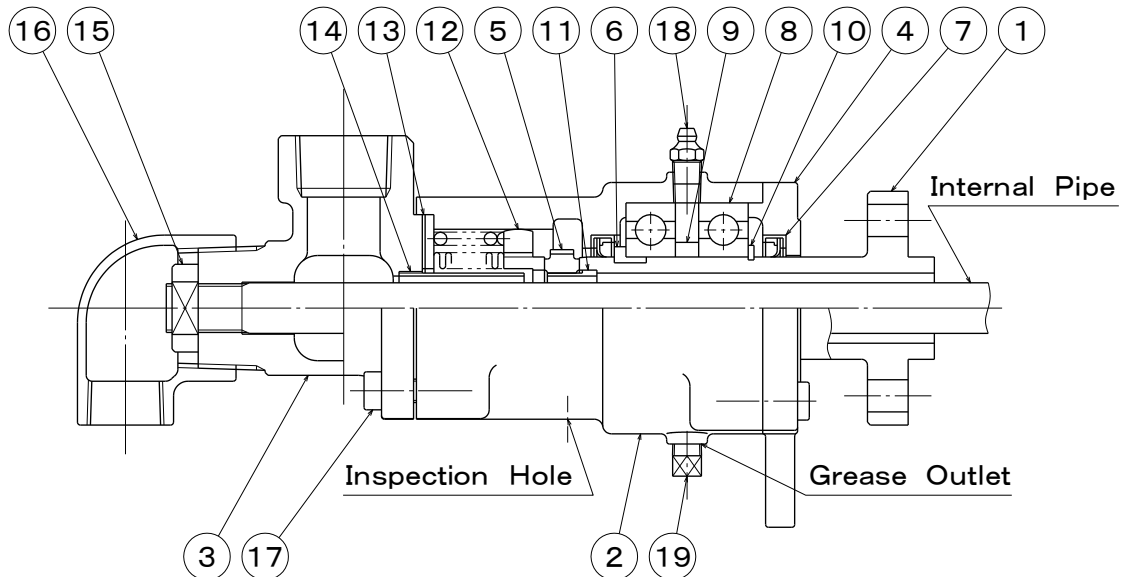

- ①Rotor ②Casing ③Head ④Cover ⑤Seal Ring ⑥Thrust collar ⑦Oil Seal ⑧Ball Bearing
 ⑨Spacer ⑩Retaining Ring ⑪Sleeve ⑫Bellows ASSY ⑬Gasket ⑭Protect Tube ⑮Lock Nut
 ⑯Elbow ⑰Cap Screw ⑱Grease Nipple ⑲Square Head Plug

< Disassembly >

Carefully disassemble the product so that each part is not damaged. In particular, be careful not to damage the seal faces of rotor ①, seal ring ⑤, and bellows ASSY ⑫.

- 1) Disconnect all pipes, etc. connected to the product.
- 2) Remove grease nipple ⑱ and square head plug ⑲.
- 3) Remove elbow ⑯ from head ③.
- 4) Remove lock nut ⑮ and the internal pipe.
- 5) Remove cap screws ⑰ and remove head ③ from casing ②.
- 6) Pull out gasket ⑬, bellows ASSY ⑫, and seal ring ⑤ from casing ②.
- 7) Remove cap screws ⑮ on the cover ④ side, and then remove the assembly consisting of rotor ①, thrust collar ⑥, ball bearings ⑧, spacer ⑨, and retaining ring ⑩ (hereinafter called the rotor assembly) from casing ②.
- 8) Remove retaining ring ⑩ from rotor ①, move ball bearings ⑧ and spacer ⑨ to the flange side, and then remove thrust collar ⑥ from rotor ①.
- 9) Remove ball bearings ⑧ and spacer ⑨ from rotor ①. Then pull out retaining ring ⑩ and cover ④ from rotor ①.
- 10) Remove oil seals ⑦ from casing ② and cover ④.

< Inspection >

Clean each part and check for damage. In particular, check the degree of wear and damage on the seal faces of rotor ①, seal ring ⑤, and bellows ASSY ⑫.

< Repair and parts replacement >

- 1) Rotor ①, seal ring ⑤, and bellows ASSY ⑫ may be reused by lapping their seal faces in case of minor damage.
- 2) Remove sleeve ⑪ before lapping the seal face of rotor ①. As sleeve ⑪ is deformed when removed, it cannot be reused. After lapping the seal face, prepare a new sleeve ⑪ and press-fit it in rotor ① so that no eccentricity exists.
- 3) Replace oil seals ⑦ and gasket ⑬ with new ones regardless of their conditions.
- 4) If repair or reuse of parts is impossible, replace them with our new genuine parts. Contact our sales representative to request genuine parts.

< Assembly >

Assemble the product in the reverse order of disassembly.

Carefully assemble the product so that each part is not damaged. In particular, be careful not to damage the seal faces. If dust adheres to the seal face, wipe it off with thinner.

- 1) Install oil seals ⑦ to casing ② and cover ④.
- 2) Put cover ④ through rotor ① and move the cover to the flange of rotor ①.
- 3) Put retaining ring ⑩ through rotor ① and move the retaining ring to the vicinity of cover ④.
- 4) Insert ball bearing ⑧, spacer ⑨, and ball bearing ⑧ to rotor ① in order, and then install thrust collar ⑥ to rotor ①. Then move ball bearing ⑧ and spacer ⑨ to the thrust collar ⑥ side, and install retaining ring ⑩.
- 5) Install the rotor assembly assembled in step 4) to casing ②.
- 6) Install cover ④ to casing ②, and evenly tighten cap screws ⑰ in a cross pattern to secure cover ④ to casing ②.
- 7) Install seal ring ⑤, bellows ASSY ⑫, and gasket ⑬ to casing ②.
- 8) Evenly tighten cap screws ⑰ in a cross pattern to secure head ③ to casing ②.
- 9) Check that rotor ① smoothly rotates.
- 10) Install grease nipple ⑱ and fill the grease through it. Continue to fill until new grease comes out from the grease outlet. After greasing, attach square head plug ⑲.
- 11) Screw the internal pipe into the product and secure it with lock nut ⑮.
- 12) Wrap seal tape around the taper thread of head ③, and then install elbow ⑯.

A-6) For duplex, stationary IP, flange connection (ACF, 80A)

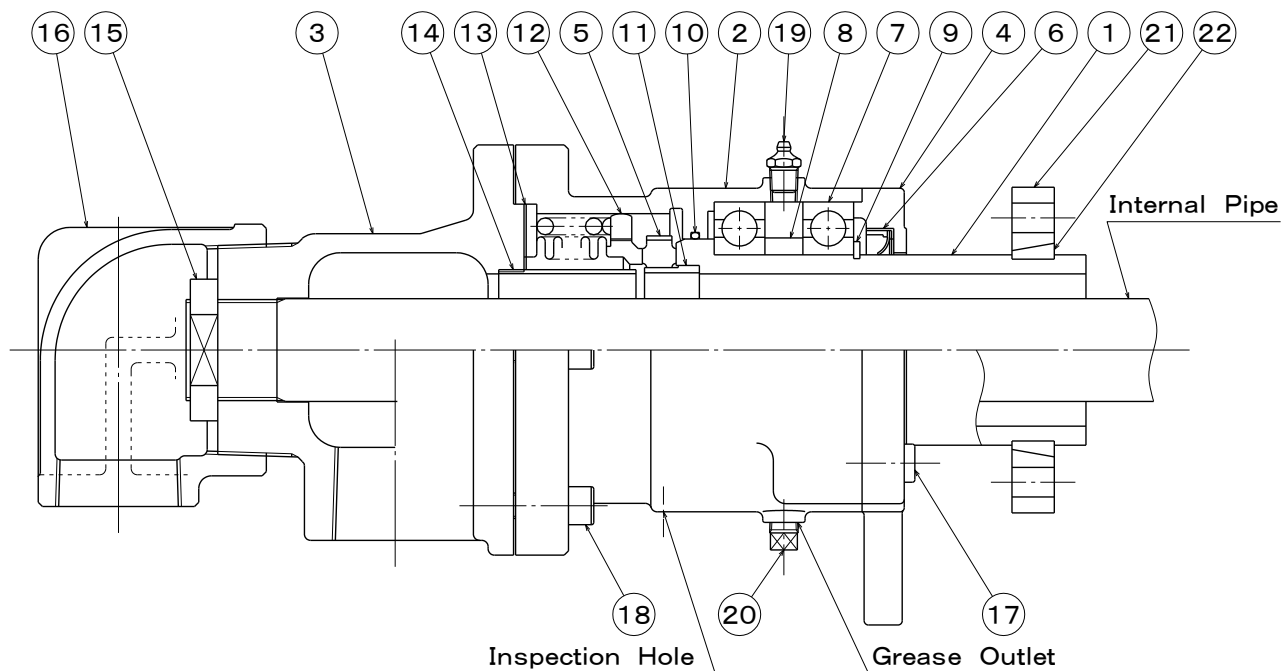

- ①Rotor ②Casing ③Head ④Cover ⑤Seal Ring ⑥Oil Seal ⑦Ball Bearing ⑧Spacer
 ⑨Retaining Ring ⑩Oil Seal (O-ring) ⑪Sleeve ⑫Bellows ASSY ⑬Gasket ⑭Protect Tube
 ⑮Lock Nut ⑯Elbow ⑰Cap Screw ⑱Cap Screw ⑲Grease Nipple ⑳Square Head Plug
 ㉑Rotor Flange ㉒Split Ring

< Disassembly >

Carefully disassemble the product so that each part is not damaged. In particular, be careful not to damage the seal faces of rotor ①, seal ring ⑤, and bellows ASSY ⑫.

- 1) Disconnect all pipes, etc. connected to the product.
- 2) Remove grease nipple ⑲ and square head plug ⑳.
- 3) Move rotor flange ㉑ to the casing ② side and remove split ring ㉒. Then pull out rotor flange ㉑ from rotor ①.
- 4) Remove elbow ⑯ from head ③.
- 5) Remove lock nut ⑮ and the internal pipe.
- 6) Remove cap screws ⑱ and remove head ③ from casing ②.
- 7) Pull out gasket ⑬, bellows ASSY ⑫, and seal ring ⑤ from casing ②.
- 8) Remove cap screws ⑰, and then remove cover ④ from casing ②.
- 9) Pull out the assembly consisting of rotor ①, ball bearings ⑦, spacer ⑧, and retaining ring ⑨ (hereinafter called the rotor assembly) from casing ②.
- 10) Remove retaining ring ⑨ from rotor ①, and then remove ball bearings ⑦ and spacer ⑧.
- 11) Remove oil seal (O-ring) ⑩ from casing ② and oil seal ⑥ from cover ④.

< Inspection >

Clean each part and check for damage. In particular, check the degree of wear and damage on the seal faces of rotor ①, seal ring ⑤, and bellows ASSY ⑫.

< Repair and parts replacement >

- 1) Rotor ①, seal ring ⑤, and bellows ASSY ⑫ may be reused by lapping their seal faces in case of minor damage.
- 2) Remove sleeve ⑪ before lapping the seal face of rotor ①. As sleeve ⑪ is deformed when removed, it cannot be reused. After lapping the seal face, prepare a new sleeve ⑪ and press-fit it in rotor ① so that no eccentricity exists.
- 3) Replace oil seal ⑥, oil seal (O-ring) ⑩, and gasket ⑬ with new ones regardless of their conditions.
- 4) If repair or reuse of parts is impossible, replace them with our new genuine parts. Contact our sales representative to request genuine parts.

< Assembly >

Assemble the product in the reverse order of disassembly.

Carefully assemble the product so that each part is not damaged. In particular, be careful not to damage the seal faces. If dust adheres to the seal face, wipe it off with thinner.

- 1) Install oil seal (O-ring) ⑩ to casing ② and oil seal ⑥ to cover ④.
- 2) Insert ball bearing ⑦, spacer ⑧, and ball bearing ⑦ to rotor ① in order, and then install retaining rings ⑨.
- 3) Install the rotor assembly assembled in step 2) to casing ②.
- 4) Install cover ④ to casing ②, and evenly tighten cap screws ⑰ in a cross pattern to secure cover ④.
- 5) Install seal ring ⑤, bellows ASSY ⑫, and gasket ⑬ to casing ②.
- 6) Install head ③ to casing ②, and evenly tighten cap screws ⑱ in a cross pattern to secure head ③.
- 7) Check that rotor ① smoothly rotates.
- 8) Insert rotor flange ⑳ into rotor ① and install split ring ㉓. Then move rotor flange ⑳ to the split ring ㉓ side.
- 9) Install grease nipple ⑲ and fill the grease through it. Continue to fill until new grease comes out from the grease outlet. After greasing, attach square head plug ㉔.
- 10) Screw the internal pipe into the product and secure it with lock nut ⑮.
- 11) Wrap seal tape around the taper thread of head ③, and then install elbow ⑯.

A-7) For duplex, rotational IP, thread connection (ACW-1/ACW-2, 25A~40A)

An explanation is given below with reference to ACW-2 (figure shown below).

* The work procedure for ACW-1 is different from that for ACW-2 as described in paragraph (●).

Seal Kit for Internal Pipe

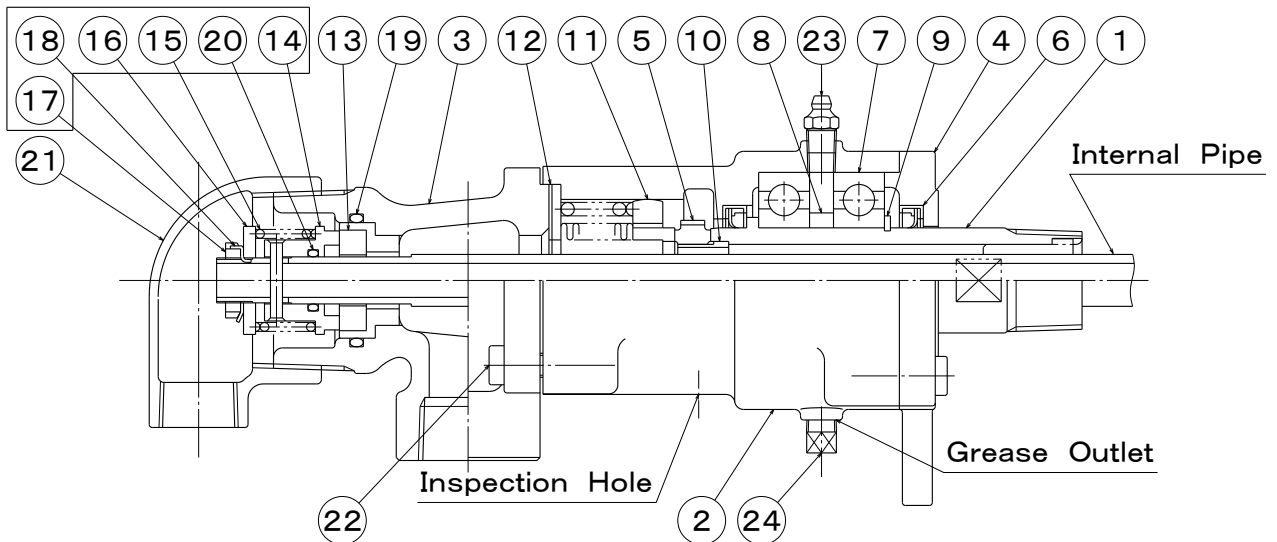

- ①Rotor ②Casing ③Head ④Cover ⑤Seal Ring ⑥Oil Seal ⑦Ball Bearing ⑧Spacer
⑨Retaining Ring ⑩Sleeve ⑪Bellows ASSY ⑫Gasket ⑬Seat Ring ⑭Rotor Ring ⑮Spring
⑯Washer ⑰Nut ⑱Washer ⑲O-ring ⑳O-ring ㉑Elbow ㉒Cap Screw ㉓Grease Nipple
㉔Square Head Plug

< Disassembly >

Carefully disassemble the product so that each part is not damaged. In particular, be careful not to damage the seal faces of rotor ①, seal ring ⑤, bellows ASSY ⑪, seat ring ⑬, and rotor ring ⑭.

- 1) Disconnect all pipes, etc. connected to the product.
- 2) Remove grease nipple ㉓ and square head plug ㉔.
- 3) Remove elbow ㉑ from head ③.
- 4) Remove the seal kit for internal pipe (⑭ to ⑱ and ㉒) in the reverse order of installation, and then remove the internal pipe.
* The installation procedure is described in "5-2) Internal pipe installation".
- 5) Remove cap screws ㉒ and remove head ③ from casing ②.
- 6) Pull out gasket ⑫, bellows ASSY ⑪, and seal ring ⑤ from casing ②.
- 7) Remove cap screws ㉒ on the cover ④ side, and then remove cover ④ from casing ②.
- 8) Pull out the assembly consisting of rotor ①, ball bearings ⑦, spacer ⑧, and retaining ring ⑨ (hereinafter called the rotor assembly) from casing ②.
- 9) Remove retaining ring ⑨ from rotor ①, and then remove ball bearings ⑦ and spacer ⑧.
- 10) Remove oil seals ⑥ from casing ② and cover ④.
- 11) Remove seat ring ⑬ and O-ring ⑲ from head ③.

(●) For ACW-1 whose internal pipe is secured to a roll, the internal pipe comes off from the product when the product is removed from the roll. Thus, steps 3) and 4) are not required.

< Inspection >

Clean each part and check for damage. In particular, check the degree of wear and damage on the seal faces of rotor ①, seal ring ⑤, bellows ASSY ⑪, seat ring ⑬, and rotor ring ⑭.

< Repair and parts replacement >

- 1) Rotor ①, seal ring ⑤, bellows ASSY ⑪, seat ring ⑬, and rotor ring ⑭ may be reused by lapping their seal faces in case of minor damage.
- 2) Remove sleeve ⑩ before lapping the seal face of rotor ①. As sleeve ⑩ is deformed when removed, it cannot be reused. After lapping the seal face, prepare a new sleeve ⑩ and press-fit it in rotor ① so that no eccentricity exists.
- 3) Replace oil seals ⑥, gasket ⑫, and O-rings ⑰ and ⑱ with new ones regardless of their conditions.
- 4) If repair or reuse of parts is impossible, replace them with our new genuine parts. Contact our sales representative to request genuine parts.

< Assembly >

Assemble the product in the reverse order of disassembly.

Carefully assemble the product so that each part is not damaged. In particular, be careful not to damage the seal faces. If dust adheres to the seal face, wipe it off with thinner.

- 1) Install O-ring ⑰ and seat ring ⑬ to head ③.
- 2) Install oil seals ⑥ to casing ② and cover ④.
- 3) Insert ball bearing ⑦, spacer ⑧, and ball bearing ⑦ to rotor ① in order, and then install retaining rings ⑨.
- 4) Install the rotor assembly assembled in step 2) to casing ②.
- 5) Install cover ④ to casing ②, and evenly tighten cap screws ⑳ in a cross pattern to secure cover ④.
- 6) Install seal ring ⑤, bellows ASSY ⑪, and gasket ⑫ to casing ②.
- 7) Install head ③ to casing ②, and evenly tighten cap screws ⑳ in a cross pattern to secure head ③.
- 8) Insert the internal pipe and install the seal kit for internal pipe (⑭ to ⑱ and ⑳).
* The installation procedure is described in "5-2) Internal pipe installation".
- 9) Check that rotor ① smoothly rotates.
- 10) Install grease nipple ㉓ and fill the grease through it. Continue to fill until new grease comes out from the grease outlet. After greasing, attach square head plug ㉔.
- 11) Wrap seal tape around the taper thread of head ③, and then install elbow ㉑.

- (●) For ACW-1, secure the internal pipe in a roll, and then install the product to the roll.
After installing the product to the roll, perform steps 8) and 11).

A-8) For duplex, rotational IP, thread connection (ACW-1/ACW-2, 50A~80A)

An explanation is given below with reference to ACW-2 65A (figure shown below).

- * The work procedure for ACW-1 is different from that for ACW-2 as described in paragraph (●).
- * The length and number of cap screws ⑫ on the rotor side are different from those on the head side.
- * If the internal pipe is 25A, use a "split pin" instead of washer ⑫ to prevent looseness of nut ⑫.

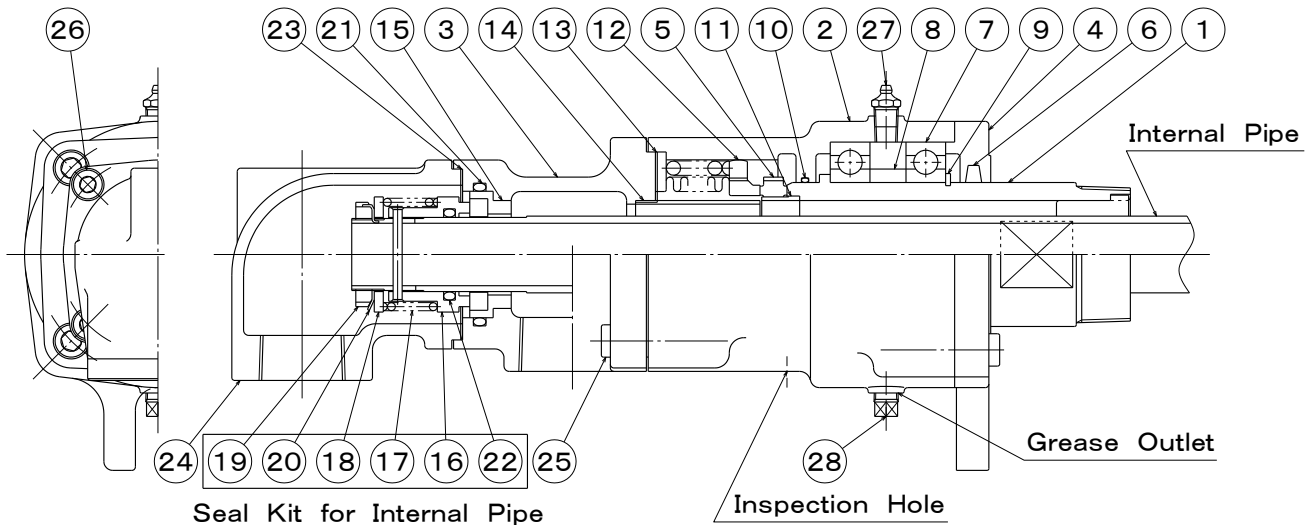

- ①Rotor ②Casing ③Head ④Cover ⑤Seal Ring ⑥Oil Seal ⑦Ball Bearing ⑧Spacer
 ⑨Retaining Ring ⑩Oil Seal (O-ring) ⑪Sleeve ⑫Bellows ASSY ⑬Gasket ⑭Protect Tube
 ⑮Seat Ring ⑯Rotor Ring ⑰Spring ⑱Washer ⑲Nut ⑳Washer ㉑O-ring ㉒O-ring
 ㉓Gasket ㉔Elbow ㉕Cap Screw ㉖Cap Screw ㉗Grease Nipple ㉘Square Head Plug

< Disassembly >

Carefully disassemble the product so that each part is not damaged. In particular, be careful not to damage the seal faces of rotor ①, seal ring ⑤, bellows ASSY ⑫, seat ring ⑮, and rotor ring ⑯.

- 1) Disconnect all pipes, etc. connected to the product.
- 2) Remove grease nipple ㉗ and square head plug ㉘.
- 3) Remove cap screws ㉖, and then remove gasket ㉓ and elbow ㉔ from head ③.
- 4) Remove the seal kit for internal pipe (⑰ to ⑳ and ㉒) in the reverse order of installation, and then remove the internal pipe.
 * The installation procedure is described in "5-2) Internal pipe installation".
- 5) Remove cap screws ㉕ and remove head ③ from casing ②.
- 6) Pull out gasket ⑬, bellows ASSY ⑫, and seal ring ⑤ from casing ②.
- 7) Remove cap screws ㉕ on the cover ④ side, and then remove cover ④ from casing ②.
- 8) Pull out the assembly consisting of rotor ①, ball bearings ⑦, spacer ⑧, and retaining ring ⑨ (hereinafter called the rotor assembly) from casing ②.
- 9) Remove retaining ring ⑨ from rotor ①, and then remove ball bearings ⑦ and spacer ⑧.
- 10) Remove oil seal (O-ring) ⑩ from casing ② and oil seal ⑥ from cover ④.
- 11) Remove seat ring ⑮ and O-ring ㉑ from head ③.

(●) For ACW-1 whose internal pipe is secured to a roll, the internal pipe comes off from the product when the product is removed from the roll. Thus, steps 3) and 4) are not required.

< Inspection >

Clean each part and check for damage. In particular, check the degree of wear and damage on the seal faces of rotor ①, seal ring ⑤, bellows ASSY ⑫, seat ring ⑮, and rotor ring ⑯.

< Repair and parts replacement >

- 1) Rotor ①, seal ring ⑤, bellows ASSY ⑫, seat ring ⑮, and rotor ring ⑯ may be reused by lapping their seal faces in case of minor damage.
- 2) Remove sleeve ⑪ before lapping the seal face of rotor ①. As sleeve ⑪ is deformed when removed, it cannot be reused. After lapping the seal face, prepare a new sleeve ⑪ and press-fit it in rotor ① so that no eccentricity exists.
- 3) Replace oil seal ⑥, gasket ⑬, O-rings ⑰ and ⑱, and gasket ⑲ with new ones regardless of their conditions.
- 4) If repair or reuse of parts is impossible, replace them with our new genuine parts. Contact our sales representative to request genuine parts.

< Assembly >

Assemble the product in the reverse order of disassembly.

Carefully assemble the product so that each part is not damaged. In particular, be careful not to damage the seal faces. If dust adheres to the seal face, wipe it off with thinner.

- 1) Install O-ring ⑰ and seat ring ⑮ to head ③.
- 2) Install oil seal (O-ring) ⑩ to casing ② and oil seal ⑥ to cover ④.
- 3) Insert ball bearing ⑦, spacer ⑧, and ball bearing ⑦ to rotor ① in order, and then install retaining rings ⑨.
- 4) Install the rotor assembly assembled in step 2) to casing ②.
- 5) Install cover ④ to casing ②, and evenly tighten cap screws ⑳ in a cross pattern to secure cover ④.
- 6) Install seal ring ⑤, bellows ASSY ⑫, and gasket ⑬ to casing ②.
- 7) Install head ③ to casing ②, and evenly tighten cap screws ⑳ in a cross pattern to secure head ③.
- 8) Insert the internal pipe and install the seal kit for internal pipe (⑰ to ⑱ and ㉑).
* The installation procedure is described in "5-2) Internal pipe installation".
- 9) Check that rotor ① smoothly rotates.
- 10) Install grease nipple ㉒ and fill the grease through it. Continue to fill until new grease comes out from the grease outlet. After greasing, attach square head plug ㉓.
- 11) Install gasket ⑲ to head ③, and evenly tighten cap screws ㉔ in a cross pattern to secure elbow ㉕.

- (●) For ACW-1, secure the internal pipe in a roll, and then install the product to the roll.
After installing the product to the roll, perform steps 8) and 11).

A-9) For duplex, rotational IP, flange connection (ACFW-1/ACFW-2 , 25A~40A)

An explanation is given below with reference to ACFW-2 (figure shown below).

* The work procedure for ACFW-1 is different from that for ACFW-2 as described in paragraph (●).

Seal Kit for Internal Pipe

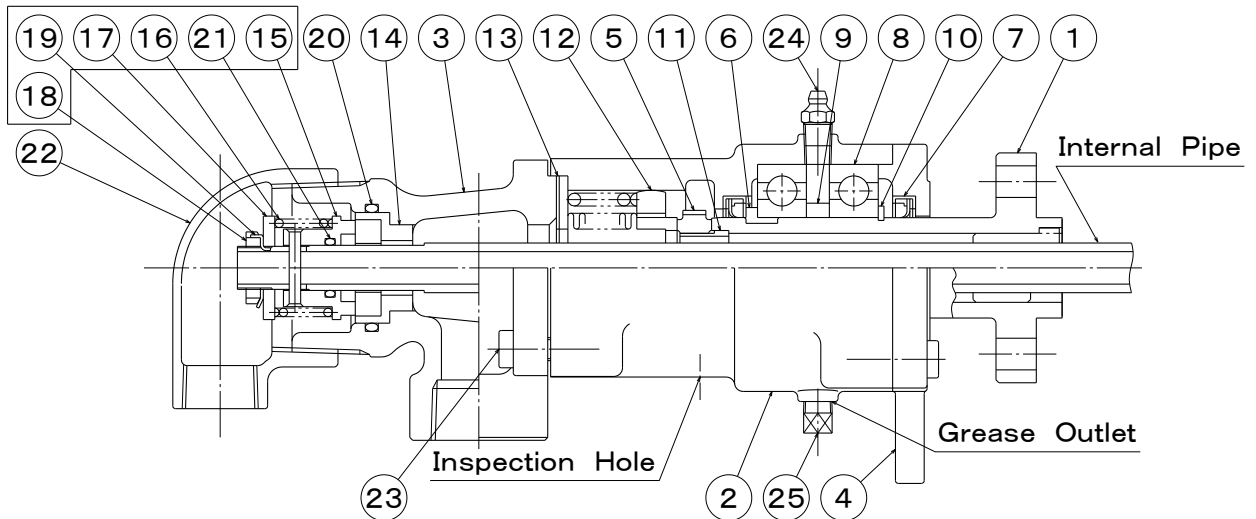

- ①Rotor ②Casing ③Head ④Cover ⑤Seal Ring ⑥Thrust Collar ⑦Oil Seal ⑧Ball Bearing
 ⑨Spacer ⑩Retaining Ring ⑪Sleeve ⑫Bellows ASSY ⑬Gasket ⑭Seat Ring ⑮Rotor Ring
 ⑯Spring ⑰Washer ⑱Nut ⑲Washer ⑳O-ring ㉑O-ring ㉒Elbow ㉓Cap Screw
 ㉔Grease Nipple ㉕Square Head Plug

< Disassembly >

Carefully disassemble the product so that each part is not damaged. In particular, be careful not to damage the seal faces of rotor ①, seal ring ⑤, bellows ASSY ⑫, seat ring ⑭, and rotor ring ⑮.

- 1) Disconnect all pipes, etc. connected to the product.
- 2) Remove grease nipple ㉔ and square head plug ㉕.
- 3) Remove elbow ㉒ from head ③.
- 4) Remove the seal kit for internal pipe (⑮ to ⑲ and ㉑) in the reverse order of installation, and then remove the internal pipe.
 * The installation procedure is described in "5-2) Internal pipe installation".
- 5) Remove cap screws ㉓ and remove head ③ from casing ②.
- 6) Pull out gasket ⑬, bellows ASSY ⑫, and seal ring ⑤ from casing ②.
- 7) Remove cap screws ㉓ on the cover ④ side, and then remove the assembly consisting of rotor ①, thrust collar ⑥, ball bearings ⑧, spacer ⑨, and retaining ring ⑩ (hereinafter called the rotor assembly) from casing ②.
- 8) Remove retaining ring ⑩ from rotor ①, move ball bearings ⑧ and spacer ⑨ to the flange side, and then remove thrust collar ⑥ from rotor ①.
- 9) Remove ball bearings ⑧ and spacer ⑨ from rotor ①. Then pull out retaining ring ⑩ and cover ④ from rotor ①.
- 10) Remove oil seals ⑦ from casing ② and cover ④.
- 11) Remove seat ring ⑭ and O-ring ⑳ from head ③.

(●) For ACFW-1 whose internal pipe is secured to a roll, the internal pipe comes off from the product when the product is removed from the roll. Thus, steps 3) and 4) are not required.

< Inspection >

Clean each part and check for damage. In particular, check the degree of wear and damage on the seal faces of rotor ①, seal ring ⑤, bellows ASSY ⑫, seat ring ⑭, and rotor ring ⑮.

< Repair and parts replacement >

- 1) Rotor ①, seal ring ⑤, bellows ASSY ⑫, seat ring ⑭, and rotor ring ⑮ may be reused by lapping their seal faces in case of minor damage.
- 2) Remove sleeve ⑪ before lapping the seal face of rotor ①. As sleeve ⑪ is deformed when removed, it cannot be reused. After lapping the seal face, prepare a new sleeve ⑪ and press-fit it in rotor ① so that no eccentricity exists.
- 3) Replace oil seals ⑦, gasket ⑬, and O-rings ⑳ and ㉑ with new ones regardless of their conditions.
- 4) If repair or reuse of parts is impossible, replace them with our new genuine parts. Contact our sales representative to request genuine parts.

< Assembly >

Assemble the product in the reverse order of disassembly.

Carefully assemble the product so that each part is not damaged. In particular, be careful not to damage the seal faces. If dust adheres to the seal face, wipe it off with thinner.

- 1) Install O-ring ㉒ and seat ring ⑭ to head ③.
- 2) Install oil seals ⑦ to casing ② and cover ④.
- 3) Put cover ④ through rotor ① and move the cover to the flange of rotor ①.
- 4) Put retaining ring ⑩ through rotor ① and move the retaining ring to the vicinity of cover ④.
- 5) Insert ball bearing ⑧, spacer ⑨, and ball bearing ⑧ to rotor ① in order, and then install thrust collar ⑥ to rotor ①. Then move ball bearing ⑧ and spacer ⑨ to the thrust collar ⑥ side, and install retaining ring ⑩.
- 6) Install the rotor assembly assembled in step 5) to casing ②.
- 7) Install cover ④ to casing ②, and evenly tighten cap screws ㉓ in a cross pattern to secure cover ④.
- 8) Install seal ring ⑤, bellows ASSY ⑫, and gasket ⑬ to casing ②.
- 9) Install head ③ to casing ②, and evenly tighten cap screws ㉓ in a cross pattern to secure head ③.
- 10) Insert the internal pipe and install the seal kit for internal pipe (⑮ to ⑲ and ㉑).
* The installation procedure is described in "5-2) Internal pipe installation".
- 11) Check that rotor ① smoothly rotates.
- 12) Install grease nipple ㉔ and fill the grease through it. Continue to fill until new grease comes out from the grease outlet. After greasing, attach square head plug ㉕.
- 13) Wrap seal tape around the taper thread of head ③, and then install elbow ㉖.

- (●) For ACFW-1, secure the internal pipe in a roll, and then install the product to the roll.
After installing the product to the roll, perform steps 10) and 13).

A-10) For duplex, rotational IP, flange connection (ACFW-1/ACFW-2 , 50A~65A)

An explanation is given below with reference to ACFW-2 (figure shown below).

* The work procedure for ACFW-1 is different from that for ACFW-2 as described in paragraph (●).

* If the internal pipe is 25A, use a “split pin” instead of washer ⑳ to prevent looseness of nut ㉔.

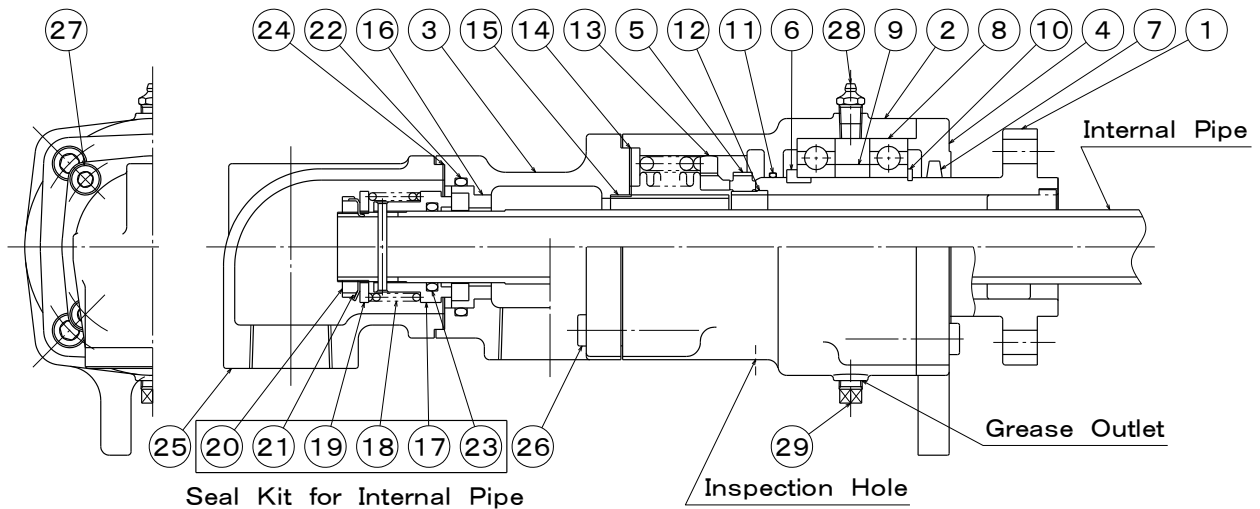

- ①Rotor ②Casing ③Head ④Cover ⑤Seal Ring ⑥Thrust Collar ⑦Oil Seal ⑧Ball Bearing
- ⑨Spacer ⑩Retaining Ring ⑪Oil Seal (O-ring) ⑫Sleeve ⑬Bellows ASSY ⑭Gasket
- ⑮Protect Tube ⑯Seat Ring ⑰Rotor Ring ⑱Spring ⑲Washer ⑳Nut ㉑Washer ㉒O-ring
- ㉓O-ring ㉔Gasket ㉕Elbow ㉖Cap Screw ㉗Cap Screw ㉘Grease Nipple
- ㉙Square Head Plug

< Disassembly >

Carefully disassemble the product so that each part is not damaged. In particular, be careful not to damage the seal faces of rotor ①, seal ring ⑤, bellows ASSY ⑬, seat ring ⑯, and rotor ring ⑰.

- 1) Disconnect all pipes, etc. connected to the product.
- 2) Remove grease nipple ㉘ and square head plug ㉙.
- 3) Remove cap screws ㉗, and then remove gasket ㉔ and elbow ㉕ from head ③.
- 4) Remove the seal kit for internal pipe (⑰ to ㉑ and ㉓) in the reverse order of installation, and then remove the internal pipe.
* The installation procedure is described in “5-2) Internal pipe installation”.
- 5) Remove cap screws ㉖ and remove head ③ from casing ②.
- 6) Pull out gasket ⑭, bellows ASSY ⑬, and seal ring ⑤ from casing ②.
- 7) Remove cap screws ㉖ on the cover ④ side, and then remove the assembly consisting of rotor ①, thrust collar ⑥, ball bearings ⑧, spacer ⑨, and retaining ring ⑩ (hereinafter called the rotor assembly) from casing ②.
- 8) Remove retaining ring ⑩ from rotor ①, move ball bearings ⑧ and spacer ⑨ to the flange side, and then remove thrust collar ⑥ from rotor ①.
- 9) Remove ball bearings ⑧ and spacer ⑨ from rotor ①. Then pull out retaining ring ⑩ and cover ④ from rotor ①.
- 10) Remove oil seal (O-ring) ⑪ from casing ② and oil seal ⑦ from cover ④.
- 11) Remove seat ring ⑯ and O-ring ㉒ from head ③.

(●) For ACFW-1 whose internal pipe is secured to a roll, the internal pipe comes off from the product when the product is removed from the roll. Thus, steps 3) and 4) are not required.

< Inspection >

Clean each part and check for damage. In particular, check the degree of wear and damage on the seal faces of rotor ①, seal ring ⑤, bellows ASSY ⑬, seat ring ⑯, and rotor ring ⑰.

< Repair and parts replacement >

- 1) Rotor ①, seal ring ⑤, bellows ASSY ⑬, seat ring ⑯, and rotor ring ⑰ may be reused by lapping their seal faces in case of minor damage.
- 2) Remove sleeve ⑫ before lapping the seal face of rotor ①. As sleeve ⑫ is deformed when removed, it cannot be reused. After lapping the seal face, prepare a new sleeve ⑫ and press-fit it in rotor ① so that no eccentricity exists.
- 3) Replace oil seal ⑦, oil seal (O-ring) ⑪, gaskets ⑭ and ⑳, and O-rings ㉒ and ㉓ with new ones regardless of their conditions.
- 4) If repair or reuse of parts is impossible, replace them with our new genuine parts. Contact our sales representative to request genuine parts.

< Assembly >

Assemble the product in the reverse order of disassembly.

Carefully assemble the product so that each part is not damaged. In particular, be careful not to damage the seal faces. If dust adheres to the seal face, wipe it off with thinner.

- 1) Install O-ring ㉒ and seat ring ⑯ to head ③.
- 2) Install oil seal (O-ring) ⑪ to casing ② and oil seal ⑦ to cover ④.
- 3) Put cover ④ through rotor ① and move the cover to the flange of rotor ①.
- 4) Put retaining ring ⑩ through rotor ① and move the retaining ring to the vicinity of cover ④.
- 5) Insert ball bearing ⑧, spacer ⑨, and ball bearing ⑧ to rotor ① in order, and then install thrust collar ⑥ to rotor ①. Then move ball bearing ⑧ and spacer ⑨ to the thrust collar ⑥ side, and install retaining ring ⑩.
- 6) Install the rotor assembly assembled in step 5) to casing ②.
- 7) Install cover ④ to casing ②, and evenly tighten cap screws ㉖ in a cross pattern to secure cover ④.
- 8) Install seal ring ⑤, bellows ASSY ⑬, and gasket ⑭ to casing ②.
- 9) Install head ③ to casing ②, and evenly tighten cap screws ㉖ in a cross pattern to secure head ③.
- 10) Insert the internal pipe and install the seal kit for internal pipe (⑰ to ㉑ and ㉓).
* The installation procedure is described in "5-2) Internal pipe installation".
- 11) Check that rotor ① smoothly rotates.
- 12) Install grease nipple ㉘ and fill the grease through it. Continue to fill until new grease comes out from the grease outlet. After greasing, attach square head plug ㉙.
- 13) Install gasket ㉔ to head ③, and evenly tighten cap screws ㉗ in a cross pattern to secure elbow ㉕.

(●) For ACFW-1, secure the internal pipe in a roll, and then install the product to the roll. After installing the product to the roll, perform steps 10) and 13).

A-11) For duplex, rotational IP, flange connection (ACFW-1/ACFW-2, 80A)

An explanation is given below with reference to ACFW-2 (figure shown below).

* The work procedure for ACFW-1 is different from that for ACFW-2 as described in paragraph (●).

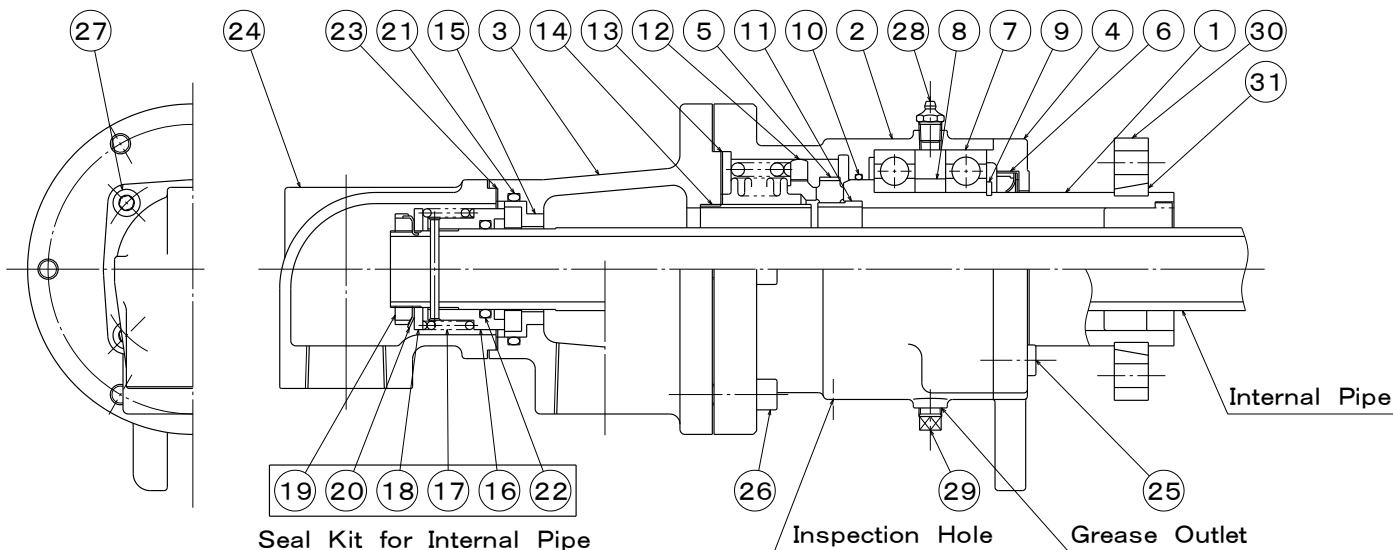

- ①Rotor ②Casing ③Head ④Cover ⑤Seal Ring ⑥Oil Seal ⑦Ball Bearing ⑧Spacer
 ⑨Retaining Ring ⑩Oil Seal (O-ring) ⑪Sleeve ⑫Bellows ASSY ⑬Gasket ⑭Protect Tube
 ⑮Seat Ring ⑯Rotor Ring ⑰Spring ⑱Washer ⑲Nut ⑳Washer ㉑O-ring ㉒O-ring
 ㉓Gasket ㉔Elbow ㉕Cap Screw ㉖Cap Screw ㉗Cap Screw ㉘Grease Nipple
 ㉙Square Head Plug ㉚Rotor Flange ㉛Split Ring

< Disassembly >

Carefully disassemble the product so that each part is not damaged. In particular, be careful not to damage the seal faces of rotor ①, seal ring ⑤, bellows ASSY ⑫, seat ring ⑮, and rotor ring ⑯.

- 1) Disconnect all pipes, etc. connected to the product.
- 2) Remove grease nipple ㉘ and square head plug ㉙.
- 3) Move rotor flange ㉚ to the casing ② side and remove split ring ㉛. Then pull out rotor flange ㉚ from rotor ①.
- 4) Remove cap screws ㉗, and then remove gasket ㉓ and elbow ㉔ from head ③.
- 5) Remove the seal kit for internal pipe (⑰ to ⑳ and ㉒) in the reverse order of installation, and then remove the internal pipe.
 * The installation procedure is described in "5-2) Internal pipe installation".
- 6) Remove cap screws ㉖ and remove head ③ from casing ②.
- 7) Pull out gasket ⑬, bellows ASSY ⑫, and seal ring ⑤ from casing ②.
- 8) Remove cap screws ㉕, and then remove cover ④ from casing ②.
- 9) Pull out the assembly consisting of rotor ①, ball bearings ⑦, spacer ⑧, and retaining ring ⑨ (hereinafter called the rotor assembly) from casing ②.
- 10) Remove retaining ring ⑨ from rotor ①, and then remove ball bearings ⑦ and spacer ⑧.
- 11) Remove oil seal (O-ring) ⑩ from casing ② and oil seal ⑥ from cover ④.
- 12) Remove seat ring ⑮ and O-ring ㉑ from head ③.

(●) For ACFW-1 whose internal pipe is secured to a roll, the internal pipe comes off from the product when the product is removed from the roll. Thus, steps 4) and 5) are not required.

< Inspection >

Clean each part and check for damage. In particular, check the degree of wear and damage on the seal faces of rotor ①, seal ring ⑤, bellows ASSY ⑫, seat ring ⑮, and rotor ring ⑯.

< Repair and parts replacement >

- 1) Rotor ①, seal ring ⑤, bellows ASSY ⑫, seat ring ⑮, and rotor ring ⑯ may be reused by lapping their seal faces in case of minor damage.
- 2) Remove sleeve ⑪ before lapping the seal face of rotor ①. As sleeve ⑪ is deformed when removed, it cannot be reused. After lapping the seal face, prepare a new sleeve ⑪ and press-fit it in rotor ① so that no eccentricity exists.
- 3) Replace oil seal ⑥, oil seal (O-ring) ⑩, gaskets ⑬ and ⑲, and O-rings ⑳ and ㉑ with new ones regardless of their conditions.
- 4) If repair or reuse of parts is impossible, replace them with our new genuine parts. Contact our sales representative to request genuine parts.

< Assembly >

Assemble the product in the reverse order of disassembly.

Carefully assemble the product so that each part is not damaged. In particular, be careful not to damage the seal faces. If dust adheres to the seal face, wipe it off with thinner.

- 1) Install O-ring ㉑ and seat ring ⑮ to head ③.
- 2) Install oil seal (O-ring) ⑩ to casing ② and oil seal ⑥ to cover ④.
- 3) Insert ball bearing ⑦, spacer ⑧, and ball bearing ⑦ to rotor ① in order, and then install retaining rings ⑨.
- 4) Install the rotor assembly assembled in step 3) to casing ②.
- 5) Install cover ④ to casing ②, and evenly tighten cap screw ㉕ in a cross pattern to secure cover ④.
- 6) Install seal ring ⑤, bellows ASSY ⑫, and gasket ⑬ to casing ②.
- 7) Install head ③ to casing ②, and evenly tighten cap screws ㉖ in a cross pattern to secure head ③.
- 8) Insert the internal pipe and install the seal kit for internal pipe (⑰ to ㉒ and ㉓).
* The installation procedure is described in "5-2) Internal pipe installation".
- 9) Check that rotor ① smoothly rotates.
- 10) Insert rotor flange ⑳ into rotor ① and install split ring ㉑. Then move rotor flange ⑳ to the split ring ㉑ side.
- 11) Install grease nipple ㉔ and fill the grease through it. Continue to fill until new grease comes out from the grease outlet. After greasing, attach square head plug ㉕.
- 12) Install gasket ⑲ to head ③, and evenly tighten cap screws ㉖ in a cross pattern to secure elbow ㉗.

- (●) For ACFW-1, secure the internal pipe in a roll, and then install the product to the roll. After installing the product to the roll, perform steps 8) and 12).