

Instruction Manual

Pearl Rotary Joint

SXO Series

This instruction manual applies to products with type designations that begin with SXO.



This instruction manual describes important precautions for preventing accidents and how to handle the product. To ensure safe use, be sure to read this manual and fully understand its contents before using this product. Store this manual carefully so that it can be referred to at any time.

Pearl is a trade name of Showa Giken Industrial Co., Ltd.

Table of Contents

1. How to Read Nameplate (Nameplate Information)	P3
2. For Safety	P3
2-1) Symbols	P3
2-2) For safe use	P3
3. Product Overview	P4
3-1) Application	P4
3-2) Information indicated by model names	P4
3-3) Service conditions	P6
3-4) Precautions for use	P6
3-5) Product structures and materials	P7
3-6) Product dimensions	P8
3-7) Product masses	P8
3-8) Accessories	P8
4. Transport and Storage	P9
4-1) Transport	P9
4-2) Storage	P9
5. Installation to Machinery	P9
5-1) Installing to a roll or spindle	P9
5-2) Pipe laying	P10
6. Removal from Machinery	P11
7. Operation	P11
7-1) Operation	P11
7-2) Operation shutdown	P11
8. Inspection and Maintenance	P12
8-1) Daily inspection	P12
8-2) Greasing	P12
8-3) Repair and replacement of consumables	P13
9. Troubleshooting	P14
10. Disposal	P15
11. Product Warranty	P15
A. Appendix – How to Repair or Replace Consumables	P17
A-1) For the 90° or straight style	P18
A-2) For the compact style	P20

1. How to Read Nameplate (Nameplate Information)

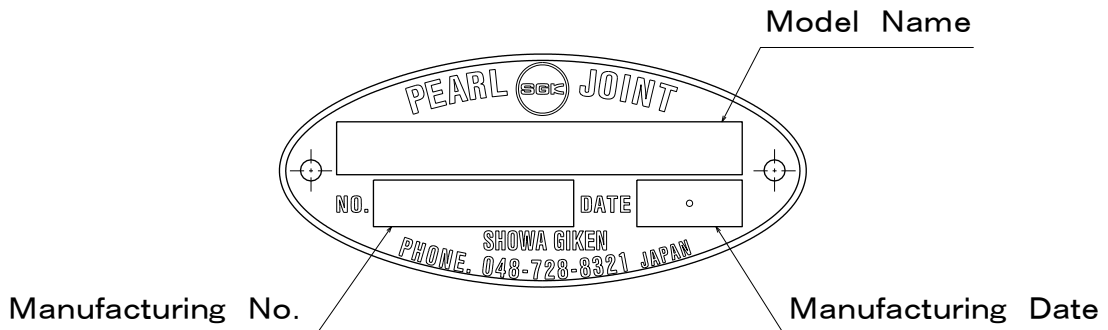

The nameplate attached to the product indicates the model name, manufacturing number, and manufacturing date.

2. For Safety

2-1) Symbols

The symbols used in this instruction manual are described below.



Indicates that failure to follow the warning message may cause bodily accidents that may result in serious or even fatal injury.



Indicates that failure to follow the caution message may cause personal injury or damage to peripheral equipment.



Indicates that failure to follow the instruction message may cause reduced product lifetime, product damage, or early leakage.



Indicates “prohibited actions”.

2-2) For safe use

1. Transport, storage, installation, piping, operation, or maintenance of this product should be carried out by an experienced expert.
2. Be sure to observe all warnings, cautions, and instructions described in each section.
3.  Never disassemble or modify this product because doing so is dangerous. We shall assume no responsibility for any malfunctions, accidents, or the results thereof involving a reassembled product after disassembly or a modified product. Also, a reassembled product after disassembly or a modified product shall not be covered by the product warranty even if the warranty period is still valid. This also applies to repairs done by yourself.
4. Confirm specifications (dimensions, materials, masses) indicated on individual product drawings before starting work. Contact our sales representative for requests for product drawings.
5. Always use the latest instruction manual. You can download the latest version from our website.

3. Product Overview

3-1) Application

A rotary joint is used for supplying fluid to or draining it from a machine rotating part called a roll, drum or cylinder, via fixed pipes.

3-2) Information indicated by model names

Information indicated by SXO series model names is described below.
The product list is shown in our catalog or on our website.

● Standard seal

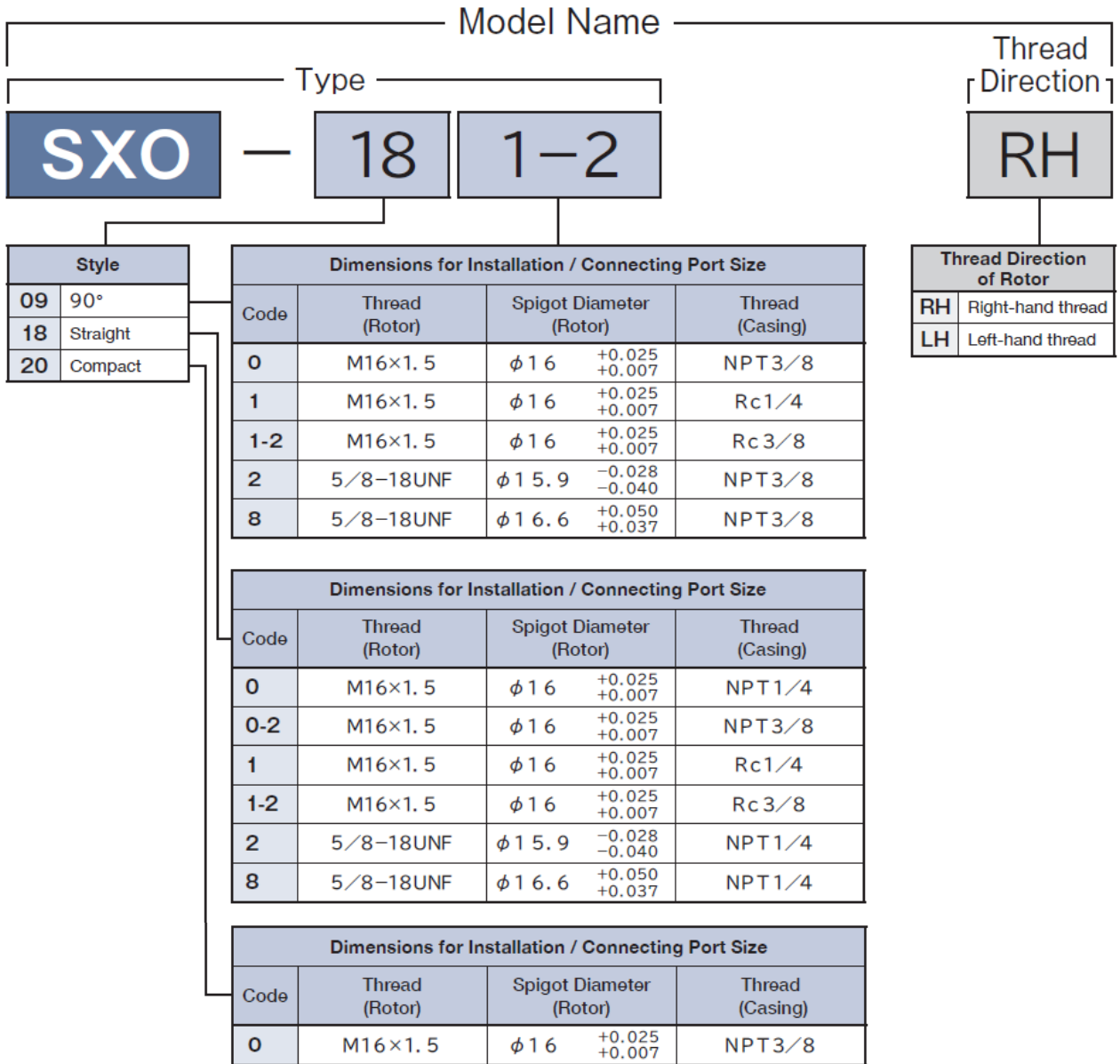

If you have any questions, contact our sales representative.

● High grade seal

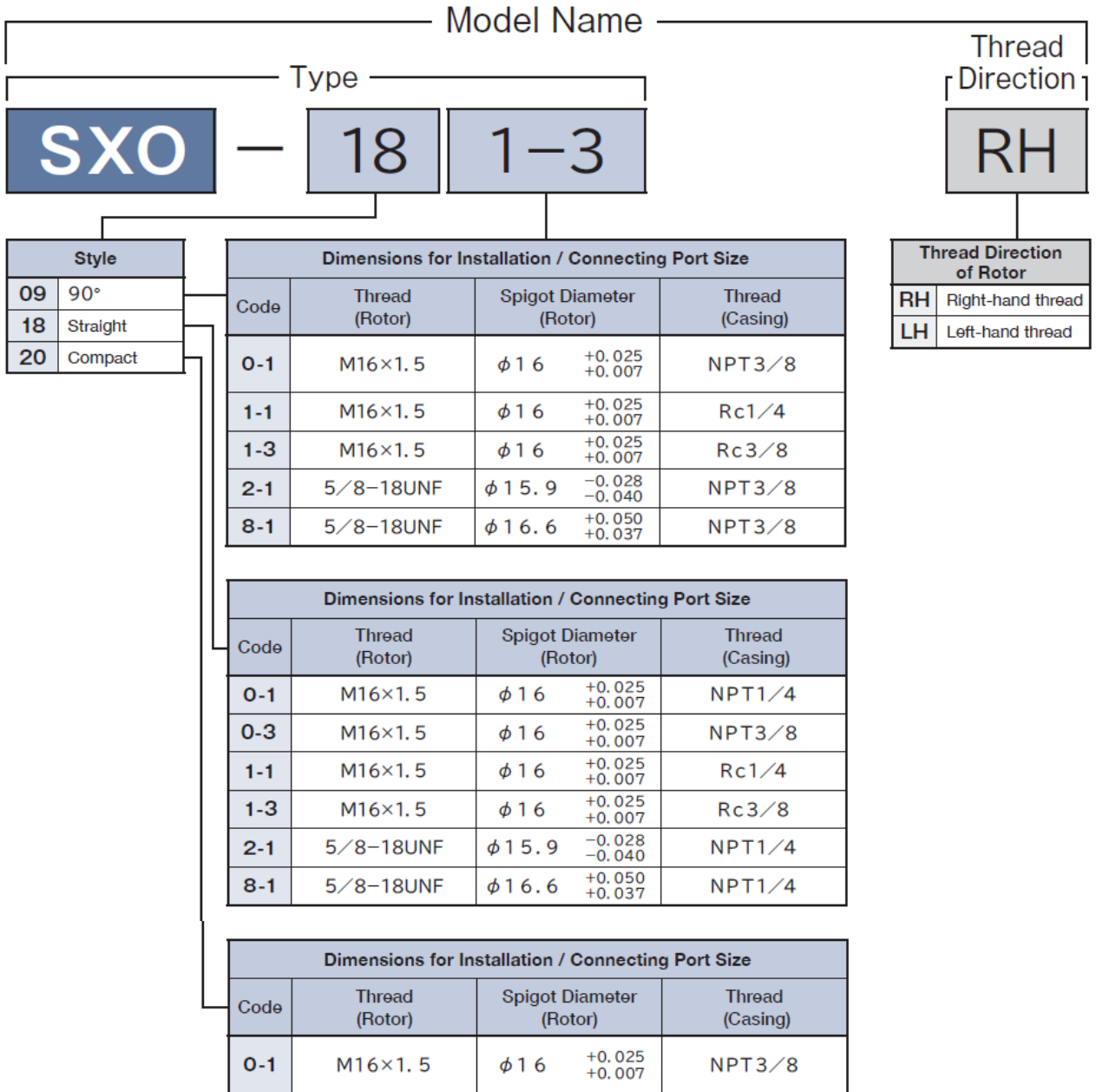

If you have any questions, contact our sales representative.



3-3) Service conditions





Service Conditions of KC Series

Series	Fluid	Style	Max.		
			Pressure (MPa)	Rotation speed (min ⁻¹)	Temperature (°C)
SXO	Cutting Oil / Water / Oil	90°	6.9	10,000	100
		Straight			
		Compact	10.3	15,000	100

3-4) Precautions for use

Use this product by following the warnings and instructions described below.

 WARNING	<ol style="list-style-type: none"> 1. If flammable fluids leak and ignite, bodily accidents including serious or even fatal injury, or accidents that damage peripheral equipment may occur due to explosion or fire. Depending on the type of fluid, this product may subject to restrictions due to national laws or local regulations. 2.  This product cannot be used for food-processing machinery. Doing so may lead to adverse health effects.
---	--

 Instruction	<ol style="list-style-type: none"> 1. Perform operation within the service conditions. 2.  Do not operate under conditions where both pressure and rotation speed are close to the max. values. Doing so significantly reduces product lifetime. 3.  This product cannot be used in temperature conditions where the product ambient temperature exceeds the upper limit of the service conditions. 4.  The product cannot be used for liquid containing solid particles (slurry) or pulverulent body. The product cannot be used for fluid that causes corrosion on it. 5.  <u>This product cannot be used for operation with no rotation, intermittent rotation, or low-rotation speed (a few rotations per minute).</u> Otherwise, fluid leakage may occur.
---	--

3-5) Product structures and materials

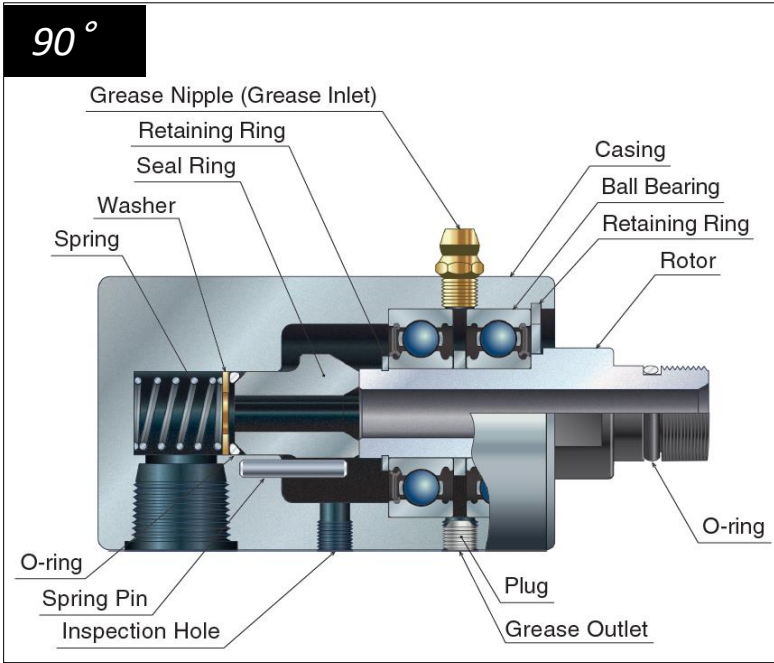

**Materials of Main Components
(Standard Seal)**

Part Name	Material
Rotor	Tool Steel
Casing	Aluminum Alloy
Seal Ring	Carbon
O-ring	NBR

The rotor is finished with electroless plating, and alumite treatment (anodizing) for the casing.

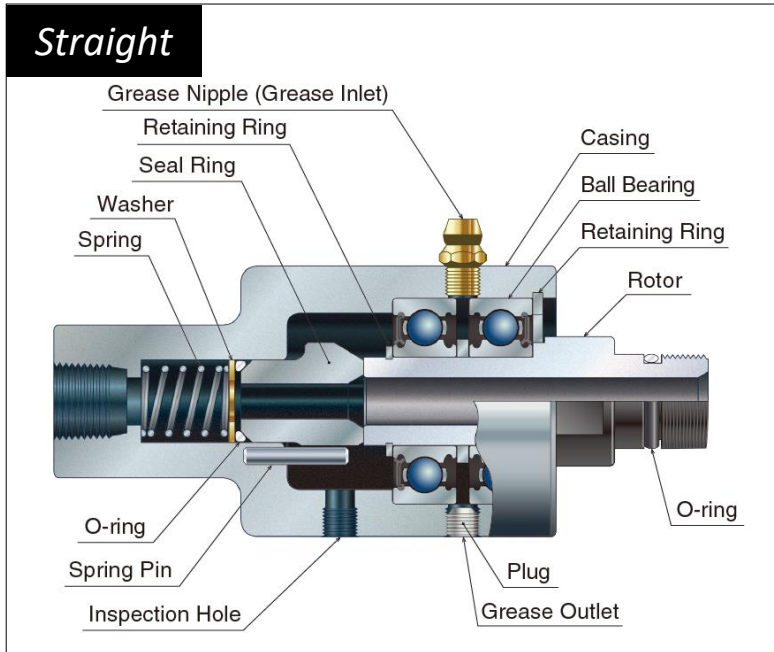

**Materials of Main Components
(Standard Seal)**

Part Name	Material
Rotor	Tool Steel
Casing	Aluminum Alloy
Seal Ring	Carbon
O-ring	NBR

The rotor is finished with electroless plating, and alumite treatment (anodizing) for the casing.

Part configuration of the straight style is the same as that of the 90° style. Only the flow passage shape is different. (The 90° style flow passage is L-shape, and the straight style flow passage is liner shape.)

● Seal configuration and materials (90° / Straight)

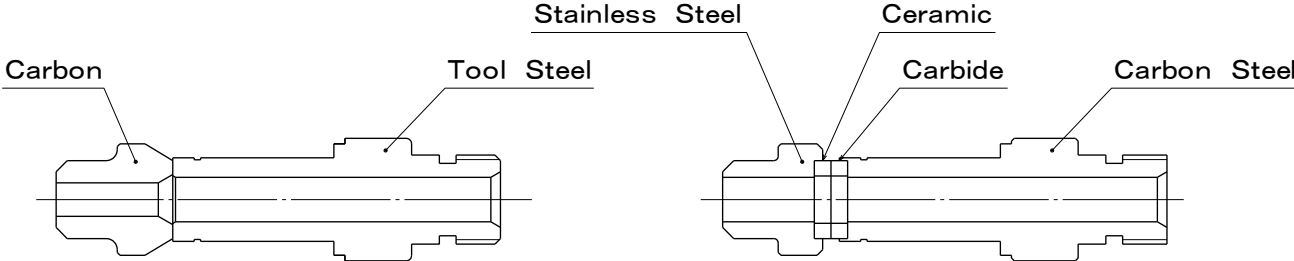

Standard Seal

High-grade Seal

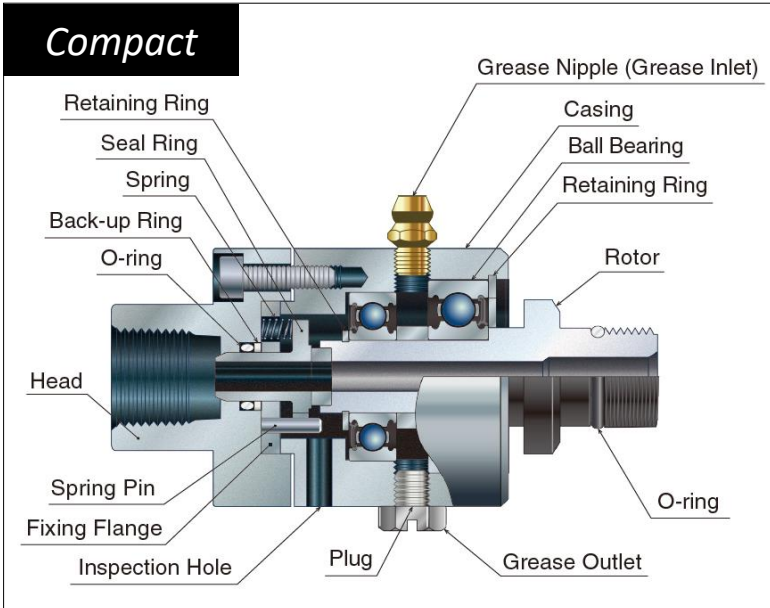

**Materials of Main Components
(Standard Seal)**

Part Name	Material
Rotor	Carbon Steel (Seal Face : Carbon)
Casing	Aluminum Alloy
Head	Aluminum Alloy
Seal Ring	Tool Steel
O-ring	NBR

The rotor is finished with electroless plating, and alumite treatment (anodizing) for the casing and head.

● Seal configuration and materials (Compact)

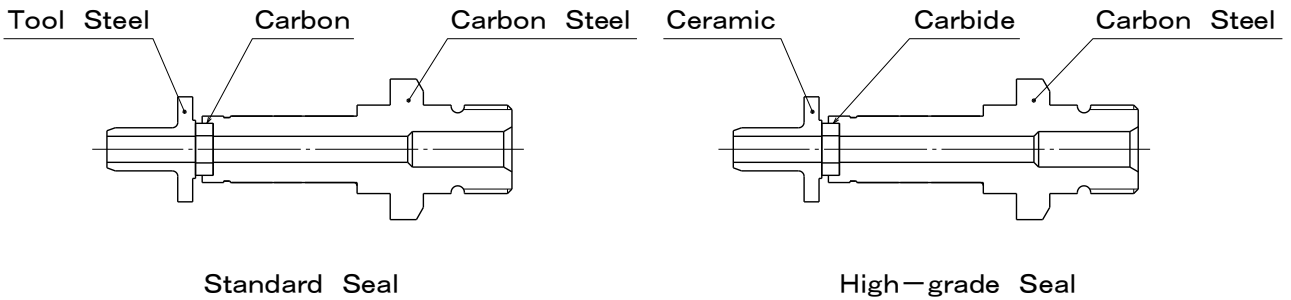

Note) Component materials are indicated on product drawings.
Contact our sales representative for requests for product drawings.

3-6) Product dimensions

Product dimensions are shown on product drawings, in our catalog, or on our website.

3-7) Product masses

Masses of SXO Series (kg)

Seal	Style		
	90°	Straight	Compact
Standard	0.39	0.34	0.28
High-grade	0.41	0.36	0.28

3-8) Accessories

Every product includes an O-ring (NBR). Its type number is AS#014 Hs90.

4. Transport and Storage

4-1) Transport

Transport this product by following the instructions described below.



Instruction

Do not subject the product to undue impact while it is being transported. Falling down or impact causes product damage (grease nipple, seal ring, etc.) or early leakage. If the product fell down or was damaged, contact us for maintenance.

4-2) Storage

An improper storage method causes product damage or early leakage.

Store this product by following the instructions described below.



Instruction

1. Wrap the product before storing it to prevent the entry of foreign objects.
2. Store this product in a dry environment at 10°C to 40°C.
3. The storage period should be within two years. If the storage period exceeds two years, contact us for maintenance.
4. If the product is stored after use, clean and then store it under the above conditions.

5. Installation to Machinery

Product adjustment is not required before installation.

5-1) Installation to roll or spindle

Install the product by following the warnings and instructions described below.



WARNING

Be sure to install the product so that an inspection hole faces downward. Also, **do not block the hole.** This hole is used for detecting leakage at an early stage. If this hole is directed toward other directions or is blocked, leakage cannot be detected at an early stage. Moreover, leaked fluid may accumulate in a casing and ball bearings may be damaged, causing serious bodily accidents due to resulting rotation failure.

Note) Inspection holes of the 90° and straight styles are blocked with plugs. Remove the plugs before use.



Instruction

1. **Remove any foreign objects in such flow passages as a pipe or a roll** before product installation. If the fluid contains foreign objects, install a strainer at the flow passages. Install a five-micron filter in the coolant supply line. Foreign objects cause early leakage.
2. If the product is installed with its center misaligned or tilted, vibration or abnormal noise may result. Moreover, the product or machine equipment may be damaged due to vibration.
3. When tightening screws or nuts, properly torque-tighten them according to the screw type or size.
4. Perform retightening after the start of use.

5-2) Pipe laying

Perform pipe laying work by following the warnings and instructions described below.





WARNING

Use a hose for product connection suitable for characteristics of fluid used and operating conditions (pressure, temperature). If an unsuitable hose is used, it may be damaged, causing injury to workers or damage to peripheral equipment.



Instruction

Observe the following instructions to prevent the generation of force applied to the sides of the product, possibly causing product damage or early leakage.

1. **Use a flexible metal tube or rubber hose with adequate flexibility.**
2.  **Steel pipes should not be used for pipe laying.**
3.  **Avoid such pipe laying where heavy items such as valves are suspended from the product.**
4. **When installing a flexible metal tube, slightly bend it in the rotation direction of roll.** (See the bottom left figure.)
5. **Carry out pipe laying work so that excessive “tension”, “compression”, “torsion”, or “bending” is not applied to a flexible metal tube.** In particular, “torsion” may significantly reduce the lifetime of the flexible metal tube. (See the bottom right figure.)
6. Use the following table as a guideline for the flexible metal tube length.

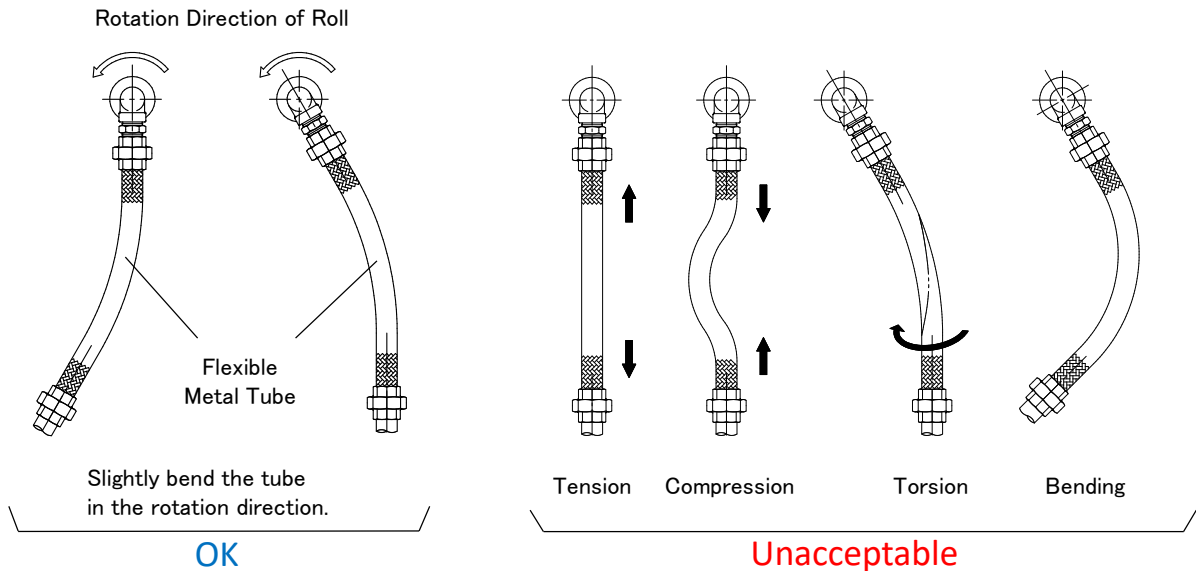

Flexible Metal Tube Length (Guideline)

(mm)

Size	8A/10A
Length	300~400

6. Removal from Machinery

Remove the product by following the warnings described below in reverse order of the installation.



WARNING

In order to prevent bodily accidents due to residual fluid in the product or pipes, remove the product after fluid has been completely drained from the product or pipes and temperature has dropped to room temperature.

7. Operation

7-1) Operation

Perform operation by following the warnings, cautions, and instructions described below.



WARNING

Immediately stop operation if fluid leakage is detected during operation. If operation is continued with fluid leakage not being repaired, serious accidents including bodily accidents may result.



CAUTION



During rotation or high-temperature/pressure fluid flow, keep well away from the product to prevent injuries or burns. Do not directly touch rotating or hot parts during operation.



Instruction

1. When starting operation, check for abnormal rotation (center runout, abnormal noise, etc.) or fluid leakage from the product while gradually increasing fluid pressure and roll rotational velocity.
2. If operation is continued under a center runout condition, product damage or fluid leakage may result.
3. The occurrence of surging or water hammer can cause product damage or fluid leakage. Avoid such occurrence.
4.  **Do not perform dry operation (operation without fluid flow) for a long time.**
The product lifetime becomes shortened.

7-2) Operation shutdown

Follow the following instructions during operation shutdown.



Instruction

1. **If the product is left as is for a long time during operation shutdown, rust may occur, causing fluid leakage after operation restart.** Clean flow passages for the product, pipes, and roll before restarting operation.
2. **If water is used as the fluid, take a measure to prevent water from freezing in the product.** Freezing may cause product damage, resulting in fluid leakage after operation restart.
3.  Do not put your hand on or ride on the product during equipment maintenance. Doing so may cause product damage or fluid leakage after operation restart.

8. Inspection and Maintenance

8-1) Daily inspection



Perform inspection according to the following instructions.

 Instruction	<ol style="list-style-type: none"> 1. Visually check pipe connections, product connections, and the product for fluid leakage. If leakage is detected, repair the product or replace it with a new one. 2. When replacing, use the same type of product with the same size.
---	---

8-2) Greasing

Periodic greasing (refilling) of ball bearings is required.

Carry out greasing according to the following instructions.

 Instruction	<ol style="list-style-type: none"> 1. Remove the grease outlet plug and fill the grease through the grease nipple (grease inlet). Continue to fill until new grease comes out from the grease outlet. 2. <u>If the grease is filled without removing the plug, parts inside the product may be damaged by the grease pressure, causing fluid leakage.</u> 3.  Use the same grease as the one filled in the product before shipment. Do not use grease mixed with other ones. Doing so may reduce the lubricating effect. 4. Carry out greasing with reference to the frequency and amount (guideline) shown in the following table. Failure to carry out greasing can reduce the lubricating performance of the grease, causing the reduction in the ball bearing lifetime.
---	---

< Grease filled in the product before shipment >

Daphne Eponex SR2 (Idemitsu Kosan) is filled in the SXO series.

Greasing Frequency
(Guideline)

Fluid Temperature (°C)	Greasing Frequency
0~60	Every six months
60~100	Every three months

Grease Amount
(Guideline) (cm³)

Style	First Time	Refill
90°	4.0	2.0~2.4
Straight		
Compact	3.5	1.7~2.1

8-3) Repair and replacement of consumables

The ball bearings and the seal face of the seal ring become worn over the course of operation time. O-rings also deteriorate. Moreover, if the internal pipe rotates in the product, bearings that support the pipe also become worn. Then such malfunctions as fluid leakage may occur. However, the product can be reused by repairing or replacing worn or deteriorated parts.

Contact us for repair or parts replacement. We carry it out according to our repair program. Depending on the products, expenses for purchasing new products may be lower than repair expenses. Consult with us when requesting repair or replacement.

< When carrying out repair or replacement of consumables by yourself >

- Repair or replacement should be carried out by an experienced expert.
- Perform work according to “A. Appendix – How to Repair or Replace Consumables”.
- Use our genuine parts as replacement parts.
Contact our sales representative to request genuine parts.
- Properly dispose of waste resulting from work according to national laws or local government regulations or ordinances.

(Attention)

If you carry out repair or replacement, we shall assume no responsibility for any product malfunctions, equipment malfunctions or accidents resulting from such product or the results thereof. Also, the product shall not be covered by the product warranty even if the warranty period is still valid.

9. Troubleshooting

This section describes the possible causes of and countermeasures against malfunctions. If a problem persists, contact our sales representative for assistance.

Malfunctions	Causes	Countermeasures
Fluid is leaking from the inspection hole.	A load is applied to the product due to an improper method of pipe laying.	Review the pipe laying method.
	The seal ring is damaged. The seal ring lifetime has been reached. The rotor seal face is damaged.	Contact us for repair.
	The fluid contains foreign objects.	Clean the inside of the product, pipes, and roll. Install a strainer.
	The O-ring adheres to the casing.	Contact us for repair.
	Operation is performed without rotation, or operation occasionally ceases during the operation cycle.	Consult with us.
	Operation is performed at low-rotation speed (a few rotations per minute).	Consult with us.
	Improper product selection.	Consult with us.
The product has center runout. (It is vibrating.)	The shaft end screw hole of a roll is offset from the roll rotation axis.	Repair the screw hole.
	The center lines of screw holes for fixing the product are inclined from the roll rotation axis.	
	The product is screwed in diagonally.	Reinstall the product.
Noise occurs.	A load is applied to the product due to an improper method of pipe laying.	Review the pipe laying method.
	Ball bearings are damaged.	Contact us for repair.
	A sliding sound is heard from the seal face.	No fault is indicated.
The rotor does not rotate.	A ball bearing does not rotate.	Contact us for repair.
Oil is leaking from a ball bearing.	Oil released from the grease seeps.	No fault is indicated.

10. Disposal

When disposing of packaging materials or products, properly dispose of them according to national laws or local government regulations or ordinances.

11. Product Warranty

If a malfunction occurs during the warranty period, contact us or the distributor and send the product to us. Be sure to carefully pack the product for protection before sending it. After receiving the product, we will confirm the malfunction. If the malfunction was clearly caused by the materials of product components or the manufacturing method, we will repair the product in question or replace it with a new one free of charge.

Product Warranty Provision

1. Warranty period

<New products>

One (1) year and six (6) months after shipment (from the manufacturing date) or one (1) year after installation, whichever comes first.

<Repaired products>

Six (6) months after shipment (from the manufacturing date).

2. We charge a fee for repairs in any of the following cases.

- ① Failure after the warranty period has expired
- ② Failure caused by use of the product deviating from the service conditions
- ③ Failure caused by misuse
(improper storage, installation, pipe laying, operation or maintenance, etc.)
- ④ Failure caused by fluid contaminants or foreign objects in the fluid
- ⑤ Failure caused by relocation, transport, or falling of the product after delivery
- ⑥ Failure caused by disassembly, repair, or modification done by personnel other than our service personnel
- ⑦ Failure of the product attributed to using materials or according to standards specified by the customer
- ⑧ Failure of the product attributed to using materials provided by the customer
- ⑨ Failure caused due to unavoidable acts of nature such as fires or other natural disasters

3. Scope of responsibility

Our responsibility shall be limited to repairs, replacements, or transport expenses covered by this product warranty provision. Expenses or damages caused by said failures above shall not be covered.

4. Applicable regions

This product warranty provision shall be applicable to products installed in Japan.

Contact our sales representative if you install and use our products outside Japan.

5. Another agreement

If another product warranty agreement is made separately with us and clearly states that said agreement shall have priority over this product warranty provision, this provision shall not be applicable.

6. This product warranty provision shall not restrict the customer's legal rights.

PEARL  **JOINT**
株式会社 昭和技研工業
SHOWA GIKEN INDUSTRIAL CO., LTD.

URL <https://www.sgk-p.co.jp>



Export Department Phone : +81-3-3598-1400 Fax. : +81-3-3598-2700
E-mail : sgk-tk@sgk-p.co.jp
Headquarters 7-24, Nishi-Kobari, Ina-Machi, Saitama, 362-0811 Japan
Phone : +81-48-728-9460 Fax. : +81-48-728-9461
Tokyo Sales Office 2-64-11, Akabane, Kita-ku, Tokyo, 115-0045 Japan
Phone : +81-3-3598-1400 Fax. : +81-3-3598-2700
Osaka Sales Office 2-9-7, Toyosaki, Kita-ku, Osaka, 531-0072 Japan
Phone : +81-6-6371-8341 Fax. +81-6-6371-6283
Nagoya Sales Office 41-1, Higashi-Ozone-cho, Higashi-ku, Nagoya, 461-0022 Japan
Phone : +81-52-938-8825 Fax. : +81-52-938-6423

A. Appendix – How to Repair or Replace Consumables

A-1) For the 90° or straight style

An explanation is given below with reference to 90° style (figure shown below).
The same workflow is applied to the straight style.

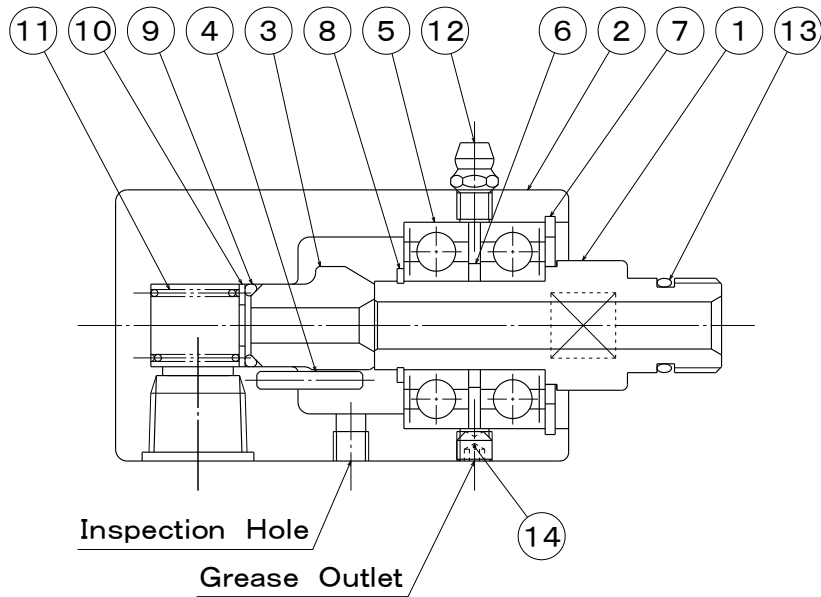

- ①Rotor ②Casing ③Seal Ring ④Spring Pin ⑤Ball Bearing
⑥Spacer ⑦Retaining Ring ⑧Retaining Ring ⑨O-ring ⑩Washer
⑪Spring ⑫Grease Nipple ⑬O-ring ⑭Plug (Set Screw)

< Disassembly >

Carefully disassemble the product so that each part is not damaged. In particular, be careful not to damage the seal faces of rotor ① and seal ring ③.

- 1) Disconnect all pipes, etc. connected to the product.
- 2) Remove grease nipple ⑫ and plug (set screw) ⑭.
- 3) Clamp casing ② with a vice, etc. so that rotor ① faces upward.
- 4) Remove retaining ring ⑦.
- 5) Pull out the assembly consisting of rotor ①, ball bearings ⑤, spacer ⑥, and retaining ring ⑧ (hereinafter called the rotor assembly) from casing ②.
- 6) Remove seal ring ③, O-ring ⑨, washer ⑩, and spring ⑪ from casing ②.
- 7) Remove retaining rings ⑧ from rotor ①, and then pull out ball bearings ⑤ and spacer ⑥.
Then remove O-ring ⑬.

< Inspection >

Clean each part and check for damage. In particular, check the degree of wear and damage on the seal faces of rotor ① and seal ring ③.

< Repair and parts replacement >

- 1) Rotor ① and seal ring ③ may be reused by lapping their seal faces in case of minor damage.
- 2) Replace O-rings ⑨ and ⑬ with new ones regardless of their conditions.
- 3) If repair or reuse of parts is impossible, replace them with our new genuine parts.
Contact our sales representative to request genuine parts.

< Assembly >

Assemble the product in the reverse order of disassembly.

Carefully assemble the product so that each part is not damaged. In particular, be careful not to damage the seal faces. If dust adheres to the seal face, wipe it off with thinner.

- 1) Apply grease to O-ring ⑨ and the inner perimeter of casing ② with which the O-ring comes in contact.
- 2) Clamp casing ② with a vice, etc. so that the rotor side faces upward.
- 3) Install spring ⑪, washer ⑩, O-ring ⑨, and seal ring ③ to casing ② in order. At this point, align the notch of seal ring ③ with spring pin ④ before installing the seal ring.
- 4) Insert ball bearing ⑤, spacer ⑥, and ball bearing ⑤ to rotor ① in order, and then install retaining rings ⑧. At this point, be sure to confirm that the direction of the ball bearings is correct.
- 5) Install the rotor assembly assembled in step 4) to casing ②.
- 6) Install retaining ring ⑦ to casing ②.
- 7) Check that rotor ① smoothly rotates.
- 8) Install grease nipple ⑫ and fill the grease through it. Continue to fill until new grease comes out from the grease outlet. After greasing, attach plug (set screw) ⑭.
- 9) Install O-ring ⑬ to rotor ①.

A-2) For the compact style

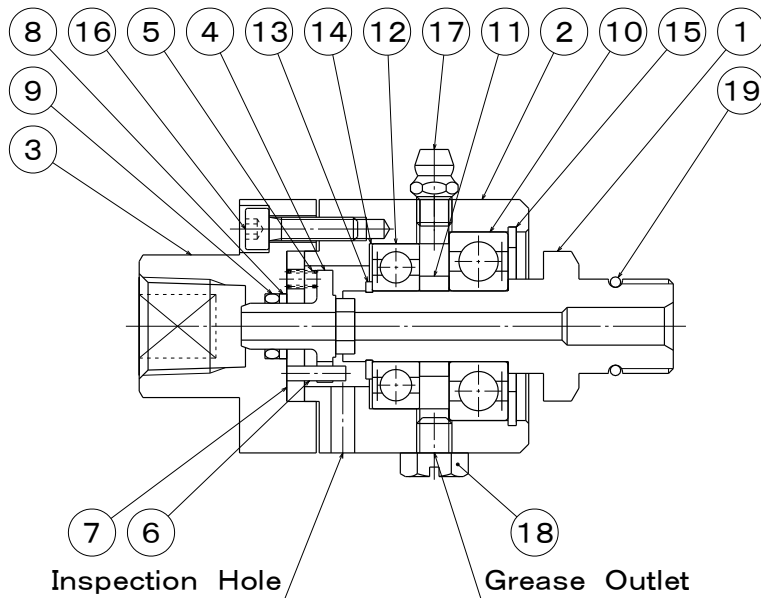

- ①Rotor ②Casing ③Head ④Seal Ring ⑤Spring ⑥Spring Pin
 ⑦Fixing Flange ⑧Buck-up Ring ⑨O-ring ⑩Ball Bearing ⑪Spacer
 ⑫Ball Bearing ⑬Retaining Ring ⑭Wave Washer ⑮Retaining Ring
 ⑯Cap Screw ⑰Grease Nipple ⑱Plug (Slotted Head Hex. Bolt) ⑲O-ring

< Disassembly >

Carefully disassemble the product so that each part is not damaged. In particular, be careful not to damage the seal faces of rotor ① and seal ring ④.

- 1) Disconnect all pipes, etc. connected to the product.
- 2) Remove grease nipple ⑰ and plug (slotted head hex. bolt) ⑱.
- 3) Clamp casing ② with a vice, etc. so that rotor ① faces upward.
- 4) Remove retaining ring ⑮.
- 5) Pull out the assembly consisting of rotor ①, ball bearings ⑩ and ⑫, spacer ⑪, and retaining ring ⑭ (hereinafter called the rotor assembly) from casing ②.
- 6) Remove wave washer ⑭, seal ring ④, and springs ⑤ from casing ②.
- 7) Remove retaining ring ⑬ from rotor ①, and then pull out ball bearings ⑩ and ⑫ and spacer ⑪. Then remove O-ring ⑲.
- 8) Secure casing ② in the opposite direction.
- 9) Remove cap screws ⑯, and then remove head ③ and fixing flange ⑦ in which spring pins ⑥ are press-fitted from casing ②.
- 10) Remove O-ring ⑨ and back-up ring ⑧ from head ③.

< Inspection >

Clean each part and check for damage. In particular, check the degree of wear and damage on the seal faces of rotor ① and seal ring ④.

< Repair and parts replacement >

- 1) Rotor ① and seal ring ④ may be reused by lapping their seal faces in case of minor damage.
- 2) Replace O-rings ⑨ and ⑲ and back-up ring ⑧ with new ones regardless of their conditions.
- 3) If repair or reuse of parts is impossible, replace them with our new genuine parts.
Contact our sales representative to request genuine parts.

< Assembly >

Assemble the product in the reverse order of disassembly.

Carefully assemble the product so that each part is not damaged. In particular, be careful not to damage the seal faces. If dust adheres to the seal face, wipe it off with thinner.

- 1) Apply grease to O-ring ⑨ and the O-ring groove of head ③.
- 2) Install back-up ring ⑧ and O-ring ⑨ to head ③.
- 3) Clamp casing ② with a vice, etc. so that the rotor side faces downward.
- 4) Install fixing flange ⑦ in which spring pins ⑥ are press-fitted and head ③, and then secure both with cap screws ⑯.
- 5) Secure casing ② in the opposite direction.
- 6) Install springs ⑤ and seal ring ④ to casing ② in order. At this point, align the notch of seal ring ④ with spring pin ⑥ before installing the seal ring. Then install wave washer ⑭.
- 7) Insert ball bearing ⑩, spacer ⑪, and ball bearing ⑫ to rotor ① in order, and then install retaining rings ⑬. At this point, be sure to confirm that the direction of the ball bearings is correct.
- 8) Install the rotor assembly assembled in step 7) to casing ②.
- 9) Install retaining ring ⑮ to casing ②.
- 10) Check that rotor ① smoothly rotates.
- 11) Install grease nipple ⑰ and fill the grease through it. Continue to fill until new grease comes out from the grease outlet. After greasing, attach plug (slotted head hex. bolt) ⑱.
- 12) Install O-ring ⑲ to rotor ①.